



CONSOLIDATED SEWING MACHINE CORP.

└ INDUSTRIAL SEWING & CUTTING EQUIPMENT

Model

206RBL-18

Operating Instructions
&
Parts Book

CONTENTS

1. MAIN PARTS NAMES	1
2. SPECIFICATIONS	1
3. WORK TABLE AND MOTOR	2
4. INSTALLATION	3
4-1. Installing the rubber hinge and the corner rubber	3
4-2. Installing the oil pan	3
4-3. Installing the machine head	3
4-4. Installing the spool pin	4
4-5. Installing the knee lifter assembly	4
4-6. Installing the belt	5
4-7. Installing the bobbin winder	5
4-8. Installing the belt guard (L)	6
4-9. Installing the thread stand	6
4-10. Lubrication	7
4-11. Checking the machine pulley rotating direction	8
5. PREPARATION BEFORE SEWING	9
5-1. Installing the needle	9
5-2. Removing the bobbin case	9
5-3. Winding the lower thread	10
5-4. Installing the bobbin case	10
5-5. Threading the upper thread	11
5-6. Adjusting the stitch length	11
6. SEWING	12
6-1. Sewing	12
6-2. Backtacking	12
7. THREAD TENSION	13
7-1. Adjusting the thread tension	13
7-2. Adjusting the presser foot pressure	13
8. STANDARD ADJUSTMENTS	14
8-1. Adjusting the thread controller spring	14
8-2. Adjusting the height of the feed dog	15
8-3. Adjusting the feed dog position (longitudinal)	15
8-4. Adjusting the positions of the needle and needle hole of the feed dog	16
8-5. Adjusting the timing the needle with feed	17
8-6. Adjusting the height of the needle bar	17
8-7. Adjusting the timing between the needle and hook	18
8-8. Adjusting the clearance between rotary hook and opener (thread release finger)	19
8-9. Adjusting the clearance between feed forked connection and feed fork collar	20
8-10. Adjusting the height of the presser feet	20
8-11. Adjusting the presser foot movement amount	21
8-12. Adjusting the timing of the vibrating presser foot	22
8-13. Adjusting the feed regulator	23
9. SAFETY CLUTCH MECHANISM	24

1. MAIN PARTS NAMES





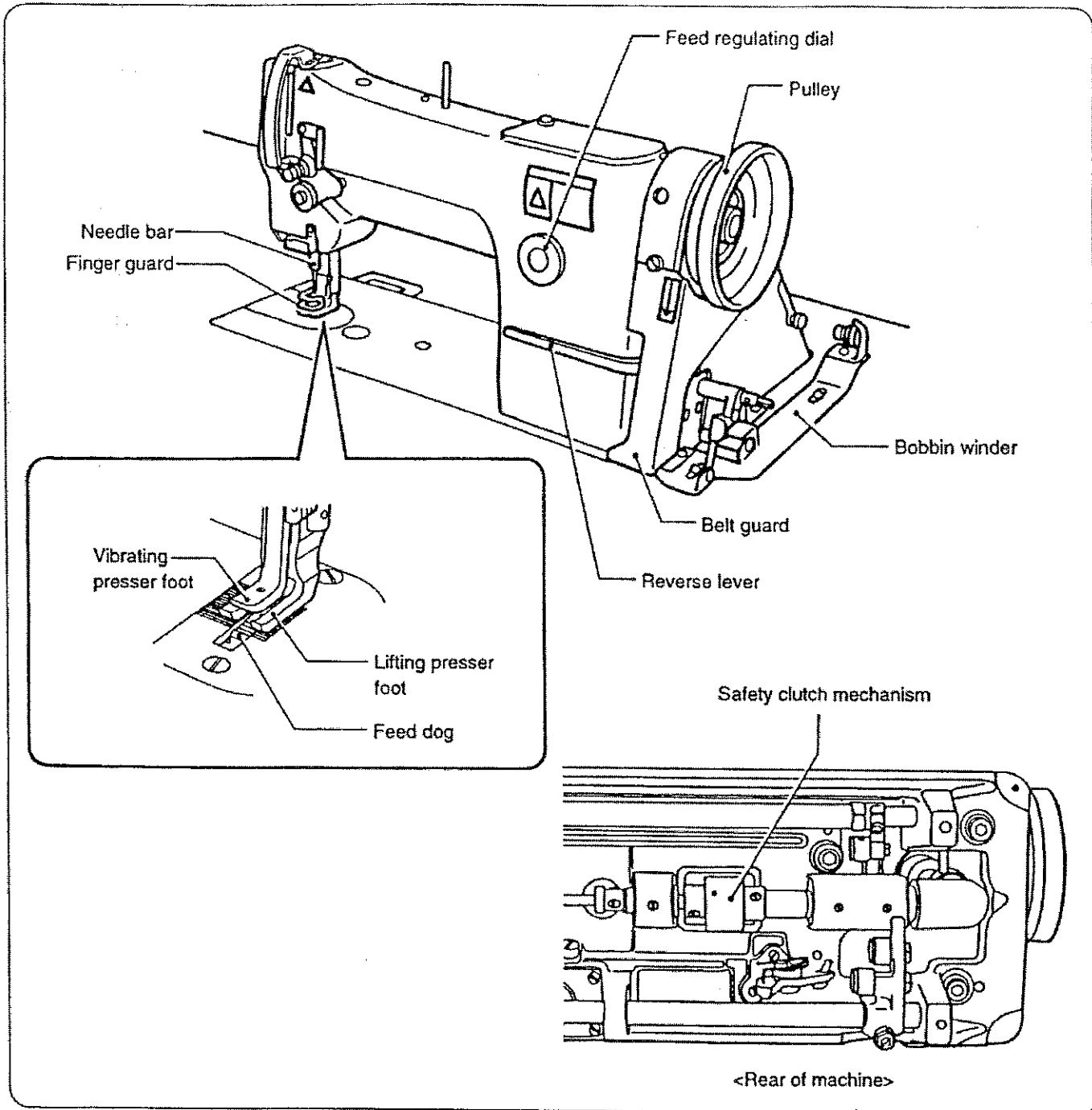

2. SPECIFICATIONS

1. MAIN PARTS NAMES



4. INSTALLATION

CAUTION

-  • The sewing machine should only be installed by a qualified technician.
-  • Ask your SEIKO dealer or a qualified electrician for any electrical work that may need to be done.
-  • The sewing machine weights more than 29 kg. The installation should be carried out by two or more people.
-  • Do not connect the power cord until installation is complete, otherwise the machine will operate if the treadle is pressed by mistake, which could result in injury.
-  • Be sure to connect the ground. If the ground connection is not secure, serious electric shocks will result.
-  • Install the belt guard to the machine head.

4-1. Installing the rubber hinge and the corner rubber

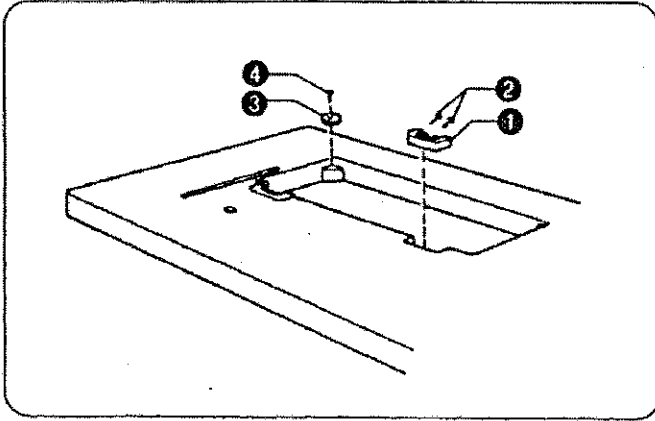

1. Install the rubber hinge ① on the table with nails ②. (Two places)
2. Install the corner rubber ③ at the four corners of the table with nails ④.

4-2. Installing the oil pan

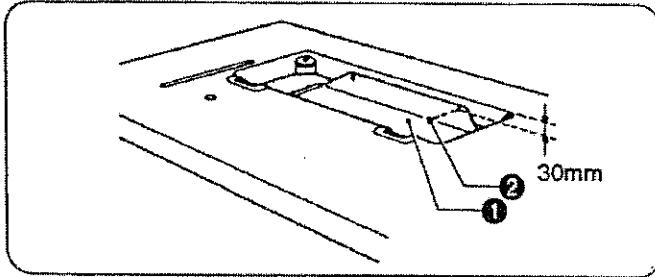

Fit oil pan ① into the opening in the table, and secure it with 4 nails ②.

(Refer to the work table processing diagram on page 2.)

4-3. Installing the machine head

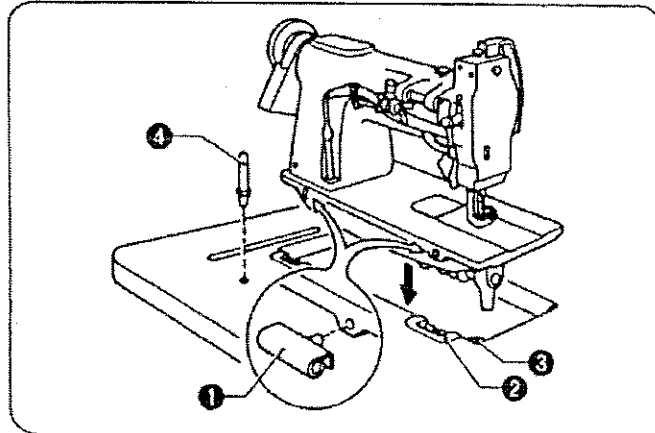

1. Insert the two bed hinge connections ① into the holes in the machine bed.
2. Fit the bed hinge connection ① to the rubber hinge ② and then place the machine head onto the corner rubber ③.
3. Tap the head rest ④ into the table hole.

NOTE: Tap the head rest securely into the table hole. If the head rest is not pushed in as far as it will go, the machine head will not be sufficiently stable when it is tilted back.

4-4. Installing the spool pin

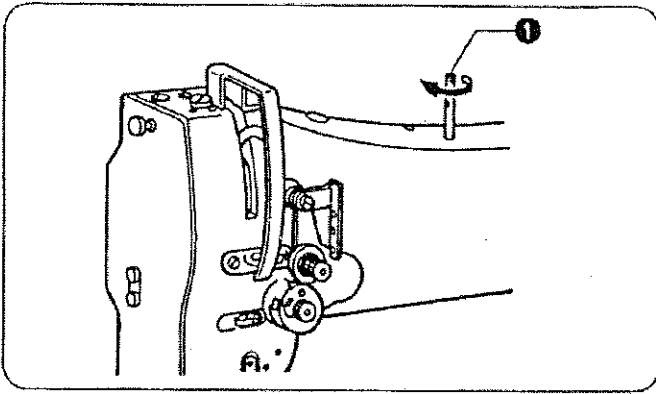

Insert the spool pin **1** into the installation hole, and screw it in tightly.

4-5. Installing the knee lifter assembly

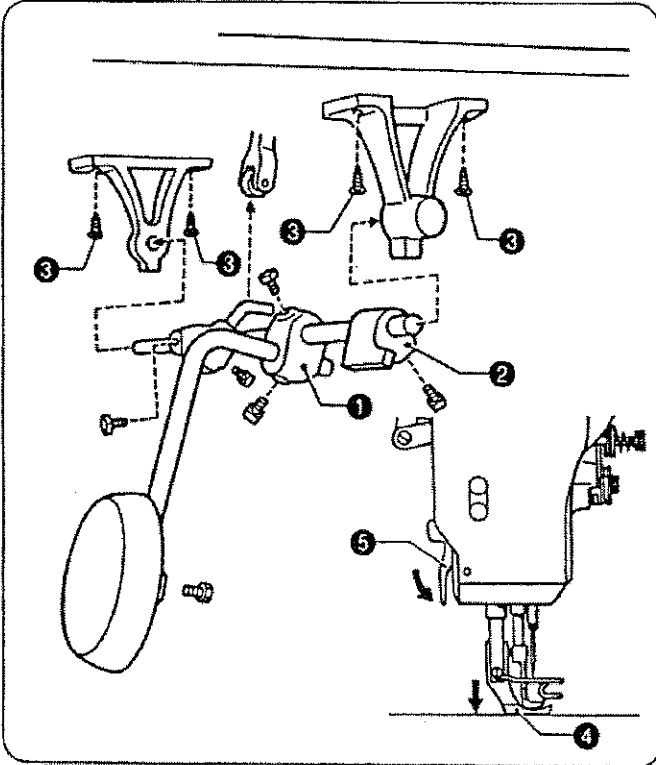

1. Assemble the knee lifter assembly **1** as shown in the illustration.

NOTE: Make sure that the knee lifter stopper **2** is facing in the correct direction.

2. Install the knee lifter assembly **1** on the back of the table with 4 screws **3**. (Refer to the work table processing diagram on page 2.)
3. Adjust the knee lifter.
 - 1) Lower the presser foot **4** by using the presser bar lifter **5**.

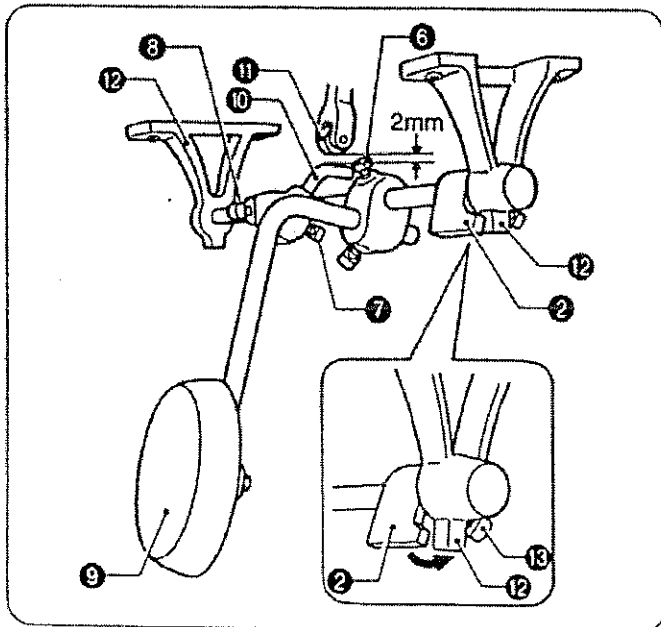

- 2) Loosen bolts **6**, **7** and **8**.
- 3) Adjust the position of the thrusting bar complete **10** so that the clearance between its curved section and the very bottom of the roller **11** is approximately 2 mm when the knee pad **9** is at the stop position.
- 4) Securely tighten bolts **6**, **7** and **8**.
- 5) Press the knee pad **9** to raise the presser foot **4** by 14 mm; then move the knee lifter stopper **2** in the direction of the arrow so that it is against the installation bracket projection **12**, securely tighten the bolt **13**.

4-6. Installing the belt

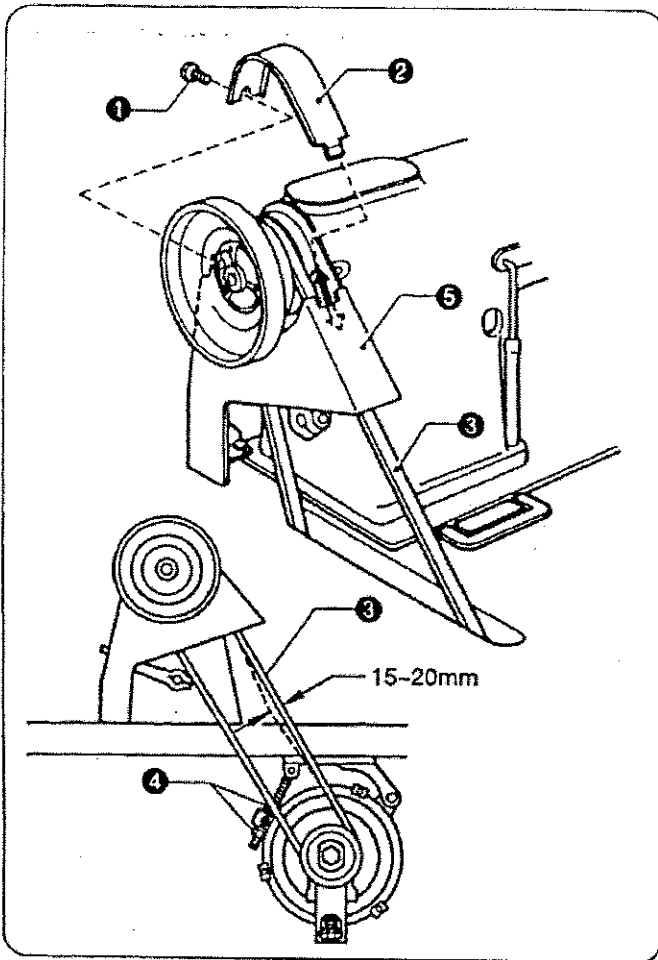

1. Remove the screw ① and remove the belt guard upper cover ②.
2. Tilt back the machine head, and then place the belt ③ onto the motor pulley and the machine pulley.
3. Turn the nut ④ to adjust so that there is 15-20 mm of deflection in the belt ③ when it is pressed with a finger with a force of 9.8 N (1 kgf).
4. Insert the belt guard upper cover ② into the belt guard ⑤ from above the pulley, and then tighten it with the screw ①.

4-7. Installing the bobbin winder

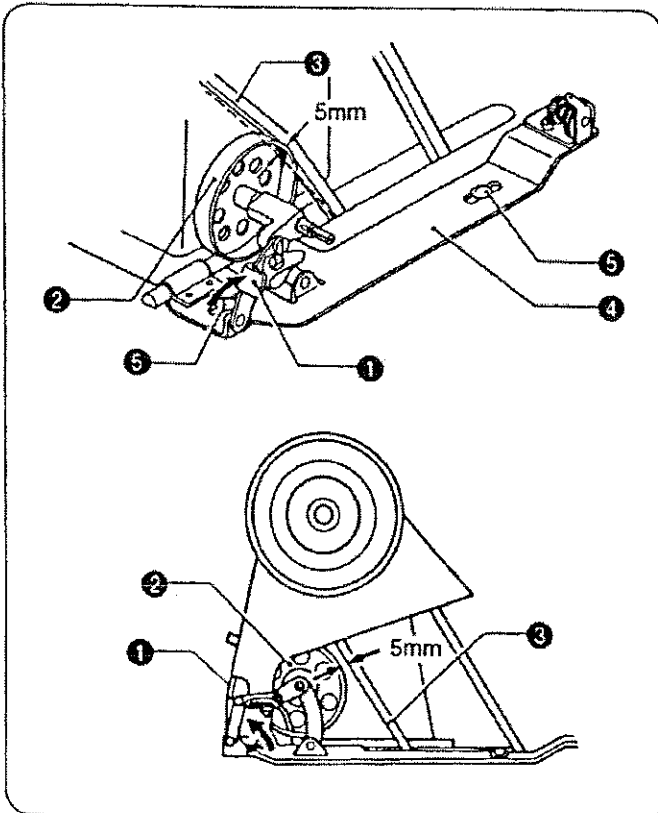

1. Push down the bobbin set lever ① as far as it will go.
2. Place the bobbin winder pulley ② so that it pushes the belt ③ by approximately 5 mm, and then place the bobbin winder ④ so that it is parallel with the belt hole in the work table.
3. Install the bobbin winder ④ to the work table with the two screws ⑤.
4. Pull the bobbin set lever ① back and check that there is approximately 5 mm of clearance between the bobbin winder pulley ② and the belt ③.

4-8. Installing the belt guard (L)

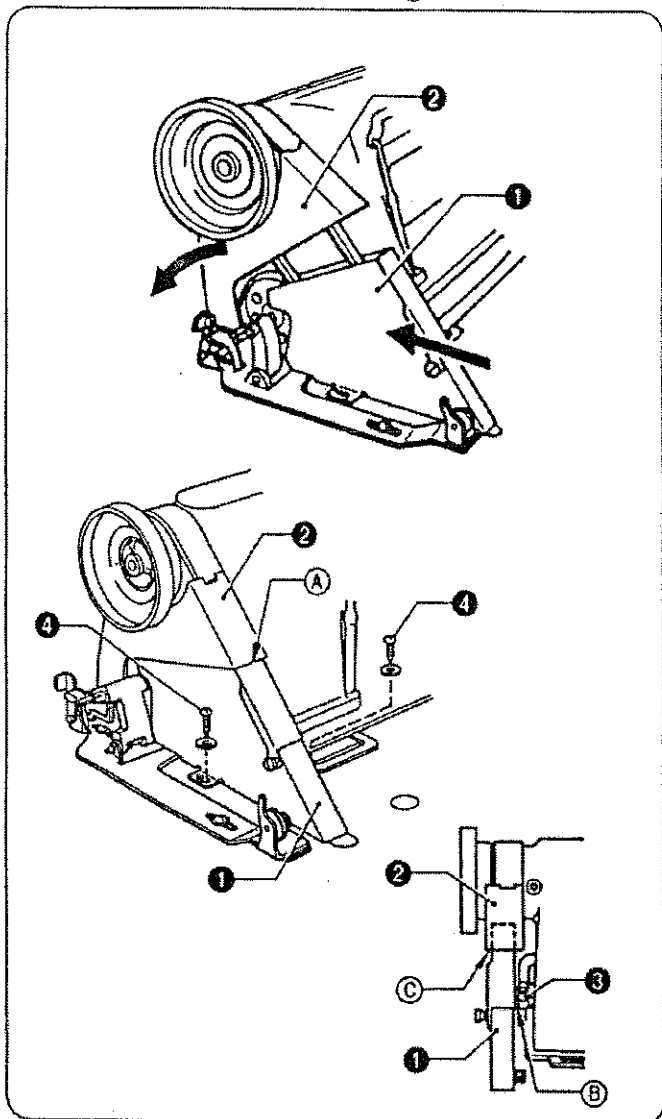

1. Tilt back the machine head, and then remove the V-belt from the motor pulley.
2. While tilting the machine forward, insert belt guard (L) ① into the belt guard ② from underneath, and let it rest there.
3. Place the V-belt back onto the pulley.
4. Install belt guard (L) ① with the two screws ④ so that there is no clearance between the belt guard ② and belt guard (L) ① (position A), and so that the reverse lever ③ and the belt guard ② are not touching (positions B and C).

4-9. Installing the thread stand

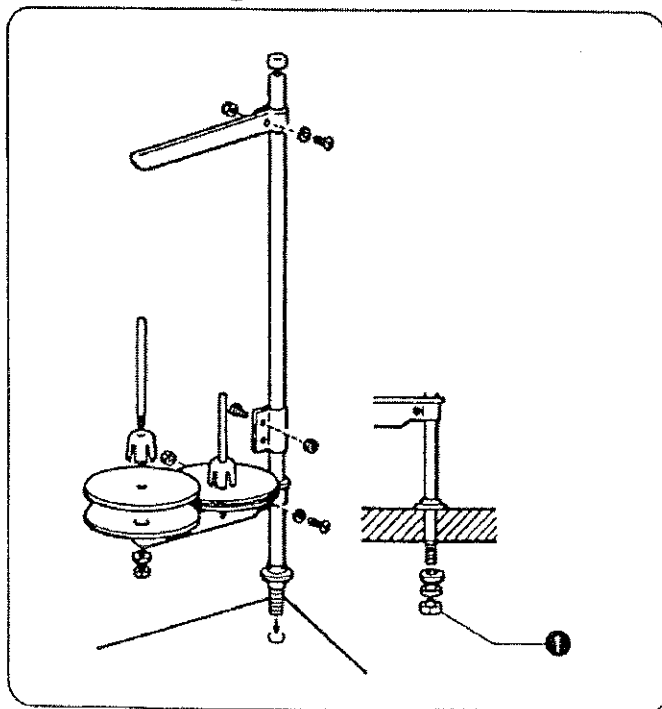



Assemble the thread stand as shown in the illustration, and then install it to the work table.

- * Securely tighten the nut ① so that the thread stand does not move.

4-10. Lubrication

CAUTION

-  Do not connect the power cord until lubrication has been completed, otherwise the machine may operate if the treadle is pressed by mistake, which could result in injury.
-  Be sure to wear protective goggles and gloves when handling the lubricating oil, so that no oil gets into your eyes or onto your skin, otherwise inflammation can result. Furthermore, do not drink the oil under any circumstances, as it can cause vomiting and diarrhoea. Keep the oil out of the reach of children.

- The sewing machine should always be lubricated and the oil supply replenished before it is used for the first time, and also after long periods of non-use.
- Use only the lubricating oil.

- Add 1-2 drops of oil in the places indicated by the arrows.
Add oil to other sliding parts also, while being careful to avoid oil leaks.
- Oiling must be done at least twice daily in continuous use.

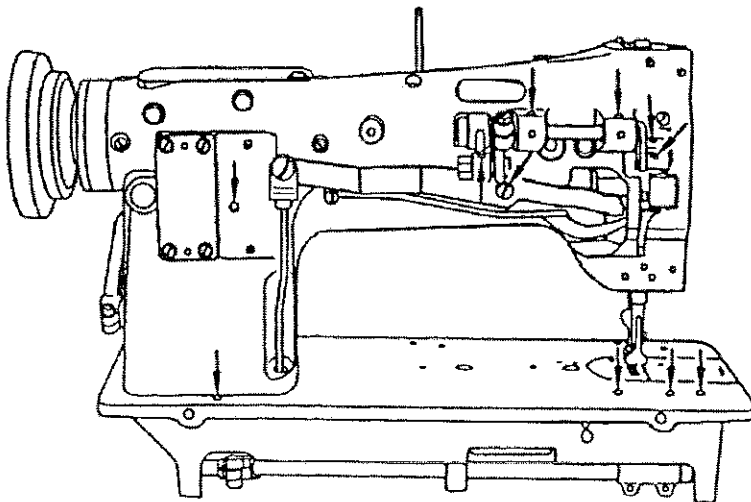
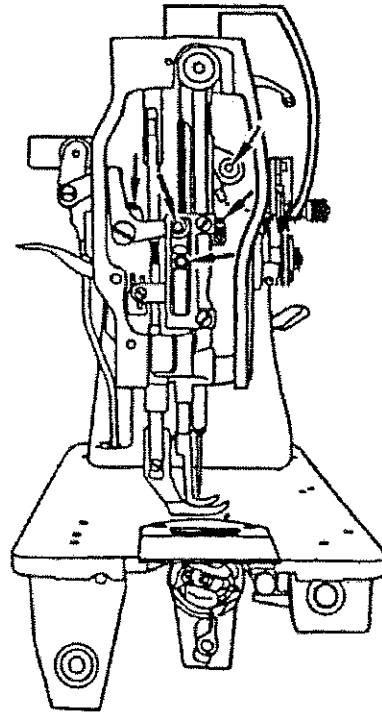
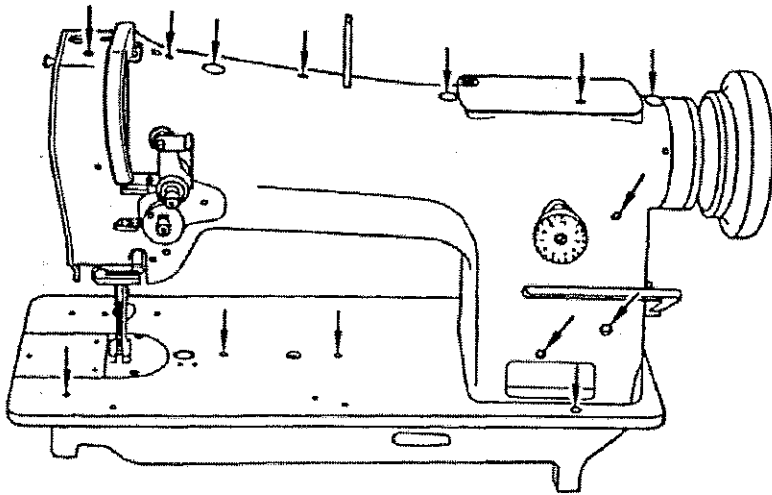

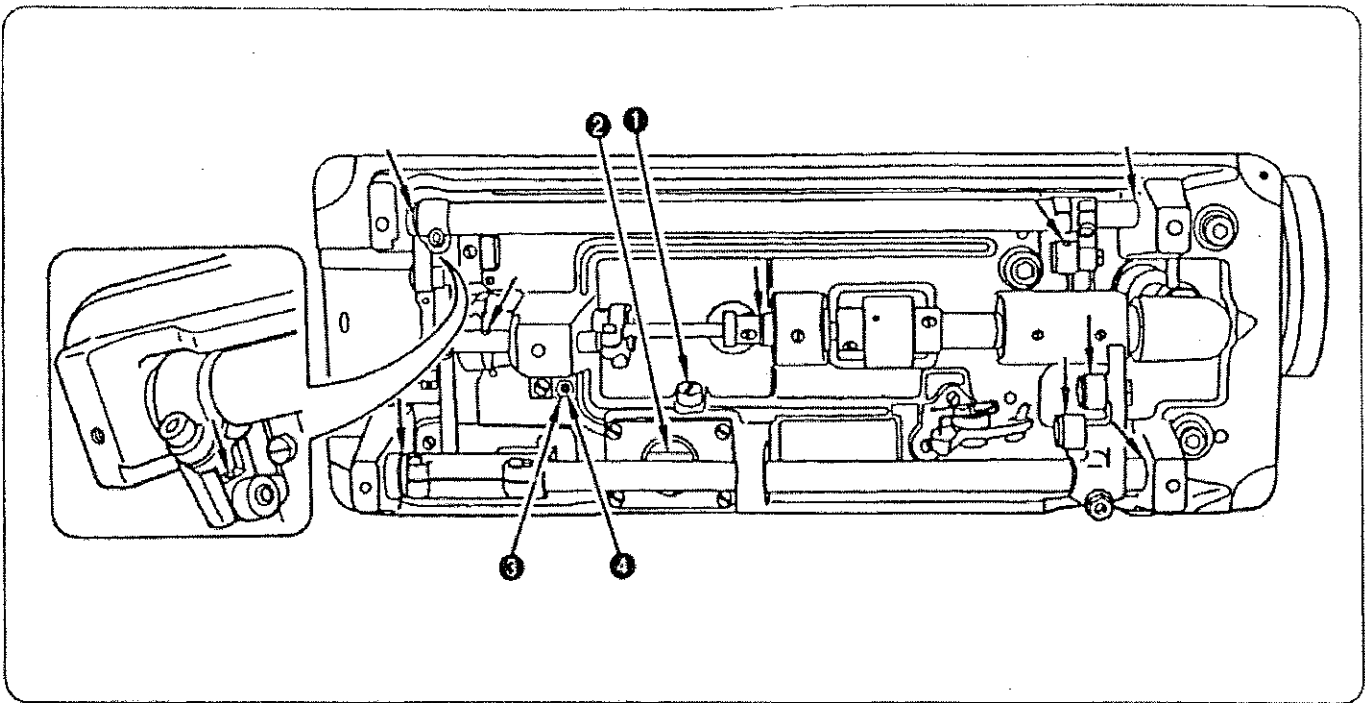

■ For oiling to hook

Remove the oil plug ① and pour oil until the oil surface reaches to the red line of the oil indicator ②. After pouring oil, tighten the oil plug ① securely.

■ Oiling adjustment to hook

Loosen the nut ③, adjust oiling by adjusting screw ④. To increase oil flow, loosen the adjusting screw ④, to decrease oil flow, tighten the screw ④. After oiling adjustments completed, tighten the nut ③ securely.

4-11. Checking the machine pulley rotating direction

⚠ CAUTION



- Do not touch any of the moving parts or place any objects against the machine while sewing, as this may result in personal injury or damage to the machine.

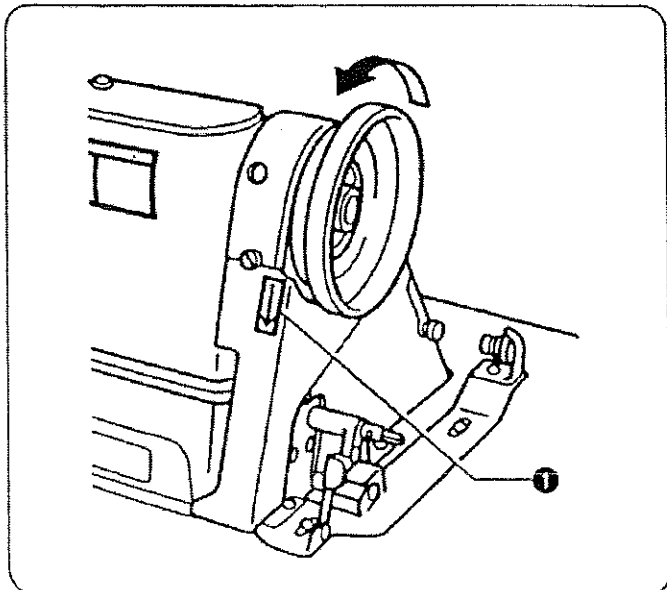

1. Insert the power cord plug into the wall outlet, and then turn on the power switch.
 2. Depress the treadle and check that the direction of rotation of the machine pulley matches the direction of the arrow ①.
- * If the direction of rotation is reversed, change the direction of rotation to the correct direction while referring to the instruction manual for the motor.

5. PREPARATION BEFORE SEWING

5-1. Installing the needle

CAUTION

-  Turn off the power switch before installing the needle. The motor will keep turning even after the power is switched off as a result of the motor's inertia. Wait until the motor stops fully before starting work. The machine may operate if the treadle is pressed by mistake, which could result in injury.

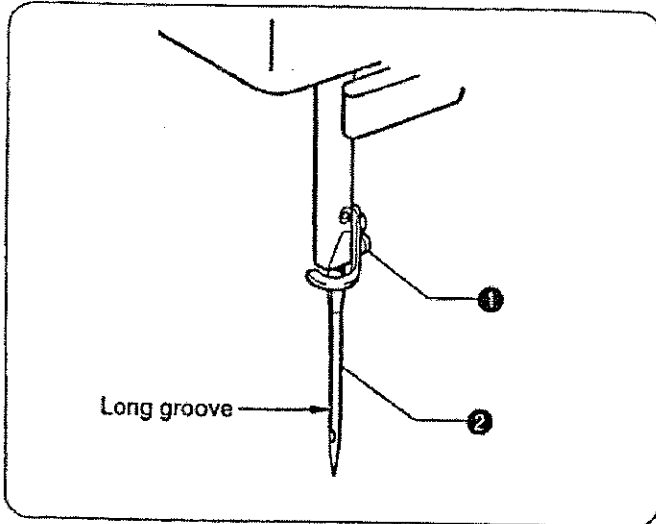

1. Turn the machine pulley toward you to move the needle bar to its highest position.
2. Loosen the screw ①.
3. Holding the needle ② with its long groove facing left, insert all the way into the needle bar.
4. Tighten the screw ①.

5-2. Removing the bobbin case

CAUTION

-  Turn off the power supply before removing the bobbin case. The motor will keep turning even after the power is switched off as a result of the motor's inertia. Wait until the motor stops fully before starting work. The machine may operate if the treadle is pressed by mistake, which could result in injury.

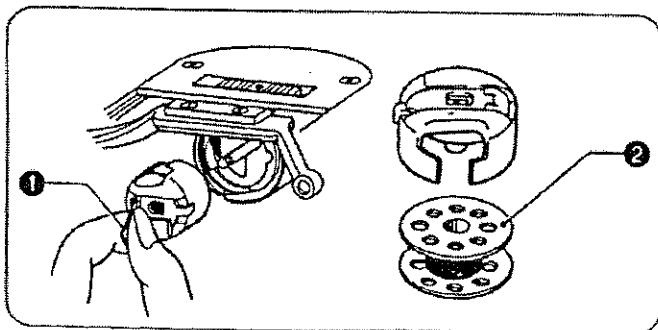

1. Open the bed slide.
2. Pull the latch ① of the bobbin case upward and then remove the bobbin case.
3. The bobbin ② will come out when the latch ① is released.

5-3. Winding the lower thread

⚠ CAUTION



- Do not touch any of the moving parts or place any objects against the machine while winding the lower thread, as this may result in personal injury or damage to the machine.

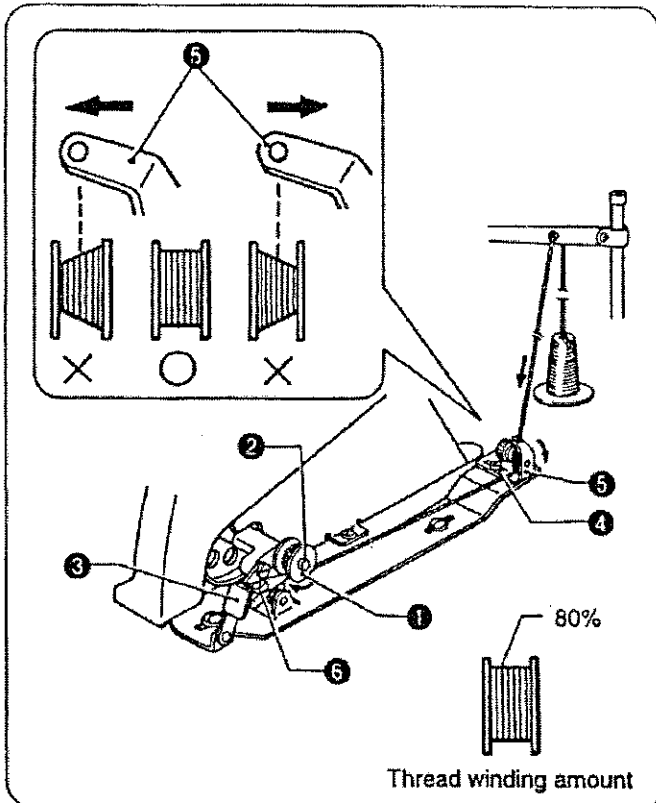

1. Turn on the power switch.
 2. Place the bobbin ① onto the bobbin winder shaft ②.
 3. Wind the thread several times around the bobbin ① in the direction indicated by the arrow.
 4. Push down the bobbin set lever ③.
 5. Raise the presser foot with the presser bar lifter.
 6. Depress the treadle. Lower thread winding will then start.
 7. Once winding of the lower thread is completed, the bobbin set lever ③ will return automatically.
- * If the thread cannot be wound on evenly, loosen the screw ④ and move the bobbin winder bracket ⑤ to the side where there is less thread.
 - * Turn the adjustment screw ⑥ to adjust the bobbin winding amount.
 - To increase the winding amount: Tighten the screw.
 - To decrease the winding amount: Loosen the screw.

Note: The amount of thread wound onto the bobbin should be a maximum of 80% of the bobbin capacity.

5-4. Installing the bobbin case

⚠ CAUTION



- Turn off the power supply before installing the bobbin case. The motor will keep turning even after the power is switched off as a result of the motor's inertia. Wait until the motor stops fully before starting work. The machine may operate if the treadle is pressed by mistake, which could result in injury.

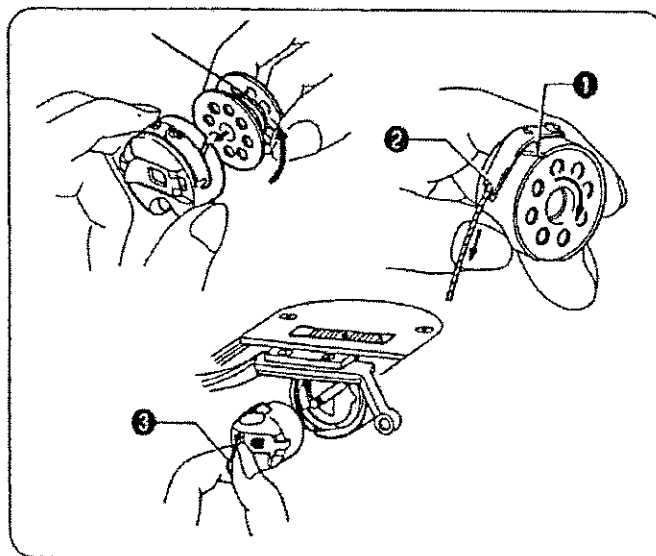

1. While holding the bobbin so that the thread winds to the right, insert the bobbin into the bobbin case.
2. Pass the thread through the slot ① and under the tension spring ②.
3. Pull the thread out through the hole in the end of the tension spring ②.
4. Check that the bobbin turns clockwise when the thread is pulled.
5. Hold the latch ③ on the bobbin case and insert the bobbin case into the rotary hook.
6. Close the bed slide.

5-5. Threading the upper thread

CAUTION



- Turn off the power switch before threading the upper thread. The motor will keep turning even after the power is switched off as a result of the motor's inertia. Wait until the motor stops fully before starting work. The machine may operate if the treadle is pressed by mistake, which could result in injury.

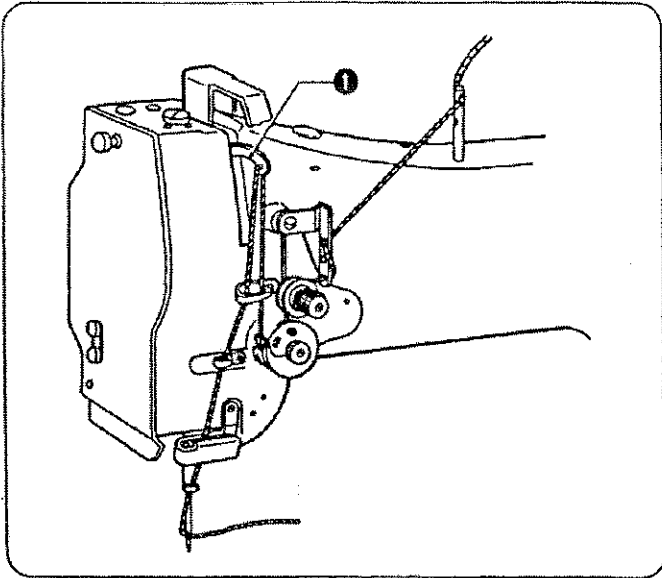

Turn the machine pulley and raise the thread take up lever **1** before threading the upper thread. This will make threading easier and it will prevent the thread from coming out at the sewing start.

5-6. Adjusting the stitch length

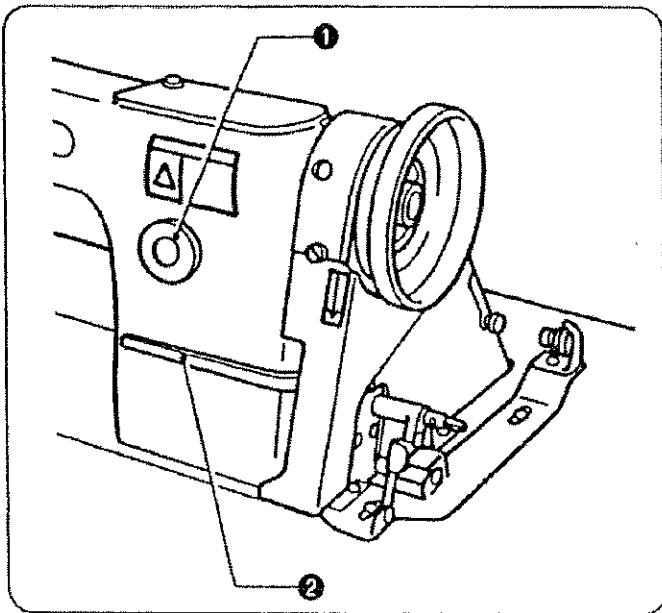



Stitch length can be set by turning the feed regulating dial **1**.

Numeric figures on the dial **1** show the stitch length in mm. The desired numeric figure on the dial **1** should be set at just above, while depressing the revers lever **2** slightly.

6. SEWING

CAUTION

-  • Attach all safety devices before using the sewing machine. If the machine is used without these devices attached, injury may result.
-  • Turn off the power switch at the following times. The motor will keep turning even after the power is switched off as a result of the motor's inertia. Wait until the motor stops fully before starting work. The machine may operate if the treadle is pressed by mistake, which could result in injury.
 - When threading the needle
 - When replacing the needle and bobbin
 - When not using the machine and when leaving the machine unattended
-  • Do not touch any of the moving parts or place any objects against the machine while sewing, as this may result personal injury or damage to the machine.

6-1. Sewing

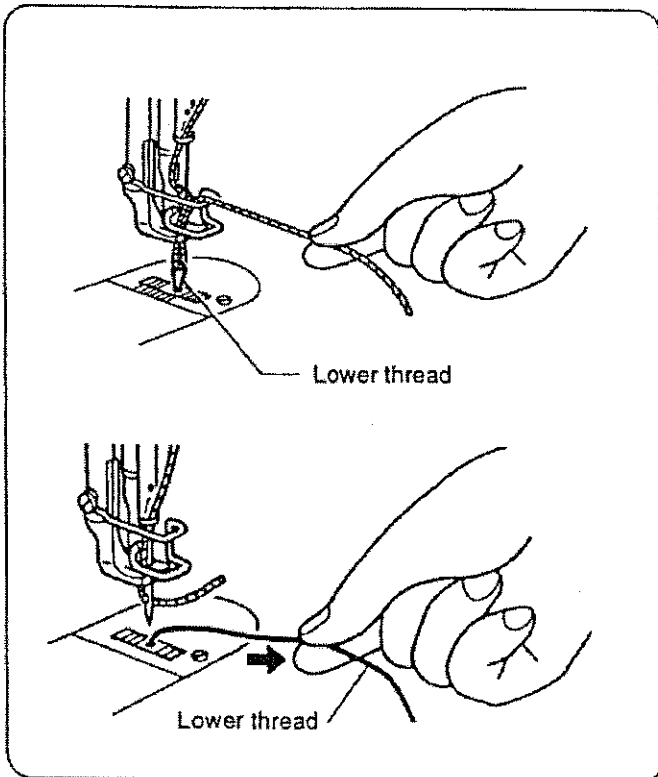

1. While holding the upper thread with your fingers, turn the machine pulley by hand toward you until the lower thread comes out onto the feed dog.
2. Pull the lower thread toward you and check that it pulls out smoothly.
3. Turn on the power switch.
4. Depress the treadle to start sewing.

6-2. Backtacking

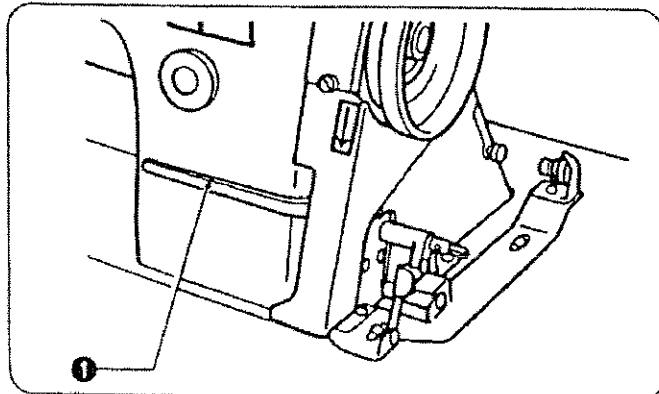

When the reverse lever **1** is pushed, the material feed direction will be reversed, and when it is returned to its original position, the feed direction will change back to normal.

7. THREAD TENSION

7-1. Adjusting the thread tension

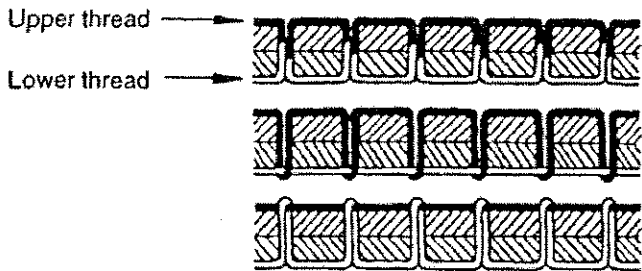

Good even stitches

Upper thread tension too weak or lower thread tension too strong

Upper thread tension too strong or lower thread tension too weak

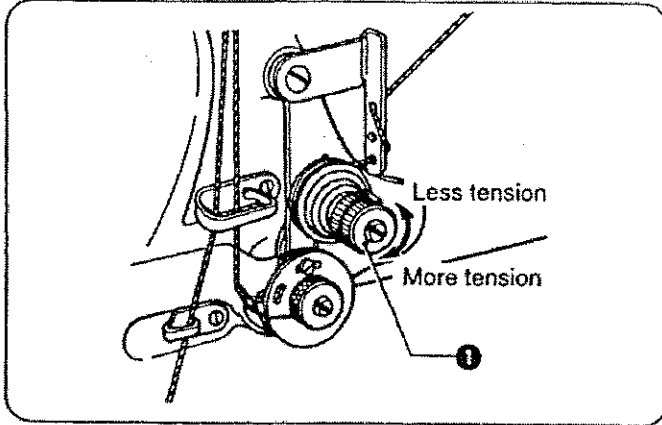



■ Upper thread tension

The tension of the upper thread is adjusted using the tension thumb nut ①.

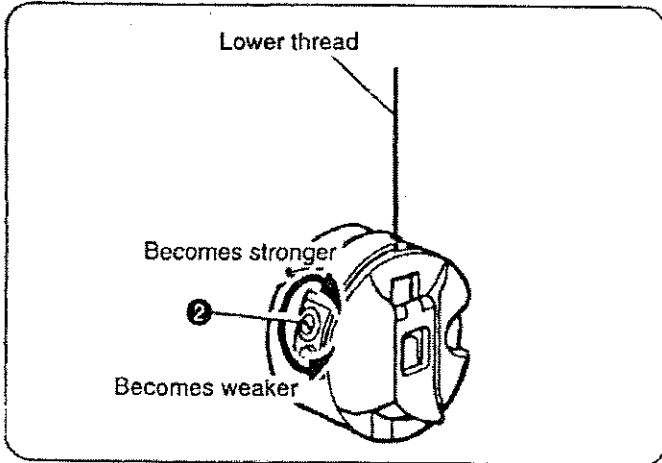
To increase the tension of the upper thread, turn the tension thumb nut ① to the right. To decrease tension, turn the tension thumb nut ① to the left.



■ Lower thread tension

 CAUTION	
	<ul style="list-style-type: none">• Turn off the power switch before removing or inserting the bobbin case. The motor will keep turning even after the power is switched off as a result of the motor's inertia. Wait until the motor stops fully before starting work. The machine may operate if the treadle is pressed by mistake, which could result in injury.

Adjust by turning the thread tension nut ② until the bobbin case will not drop by its own weight while the thread end coming out of the bobbin case is held.

7-2. Adjusting the presser foot pressure

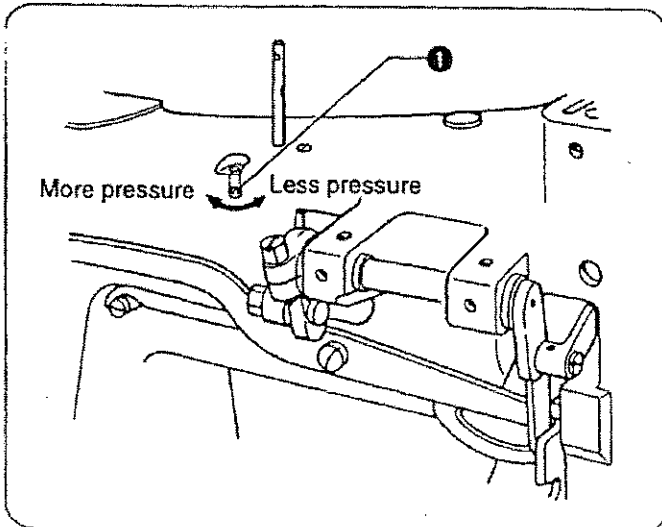

Adjust the presser foot pressure to lower as much as possible so that the presser foot can properly hold down material by turning the screw ①.

8. STANDARD ADJUSTMENTS

⚠ CAUTION

- ⊘ Maintenance and inspection of the sewing machine should only be carried out by qualified personnel.
 - ! Ask your SEIKO dealer or a qualified electrician to carry out any maintenance and inspection of the electrical system.
 - ! If any safety devices have been removed, be absolutely sure to re-install them to their original positions and check that they operate correctly before using the machine.
- ⚠ Turn off the power switch and disconnect the power cord from the wall outlet at the following times, otherwise the machine may operate if the treadle is pressed by mistake, which could result in injury. However, the motor will keep turning even after the power is switched off as a result of the motor's inertia. Wait until the motor stops fully before starting work.
 - When carrying out inspection, adjustment and maintenance
 - When replacing consumable parts such as the rotary hook
 - ⚠ If the power switch needs to be left on when carrying out some adjustment, be extremely careful to observe all safety precautions.

8-1. Adjusting the thread controller spring

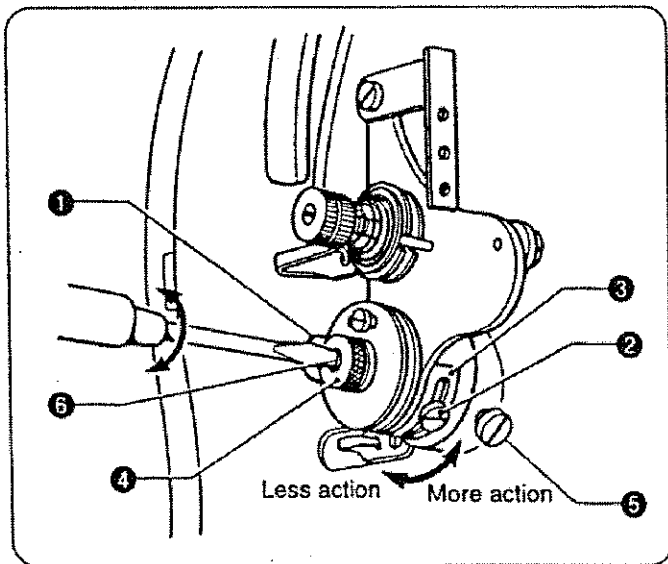

■ Operating range of spring

The standard operating range for spring ① is 5-10mm.

1. Loosen the screw ②, and then turn the thread controller spring stop ③ to adjust the operating range.
 - For more operating range, move the spring stop ③ to the right.
 - For less operating range, move the spring stop ③ to the left.
2. Tighten the screw ②.

■ Tension of the spring

The standard tension for spring ① is 0.39-0.78 N (40-80g).

1. Loosen the tension thumb nut ④ and screw ⑤.
2. Turn the tension stud ⑥ to adjust the tension.
 - To increase the spring tension, slightly turn the tension stud ⑥ counterclockwise.
 - To decrease the tension, turn the stud clockwise.
3. After adjustment, tighten the tension thumb nut ④ and screw ⑤.

8-2. Adjusting the height of the feed dog

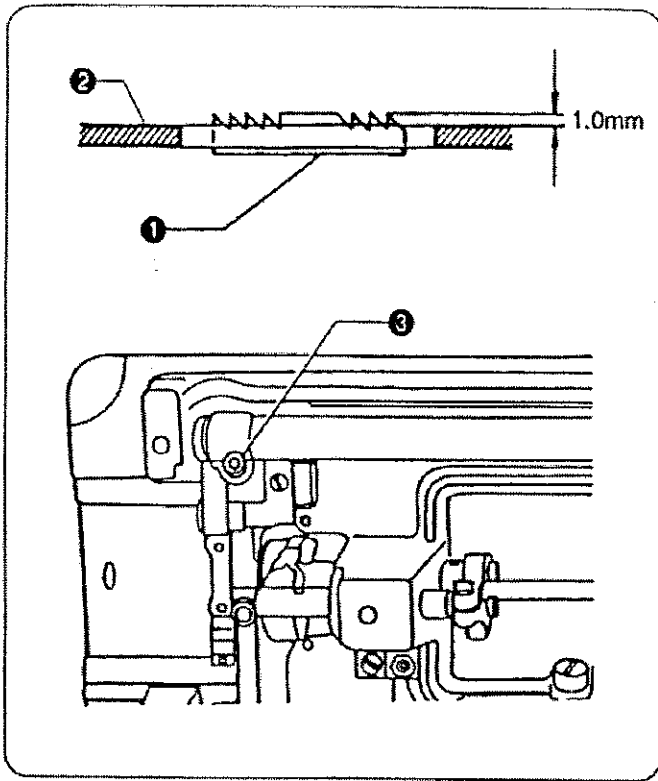

The maximum height of the feed dog ① from the surface of the needle plate ② is normally 1 mm. To adjust the height of the feed dog:

1. Tilt the machine head away from you. Turn the pulley to raise the feed dog ① to its highest position.
2. Loosen the screw ③.
3. Raise or lower the feed dog ① as necessary.
4. Tighten the screw ③.

8-3. Adjusting the feed dog position (longitudinal)

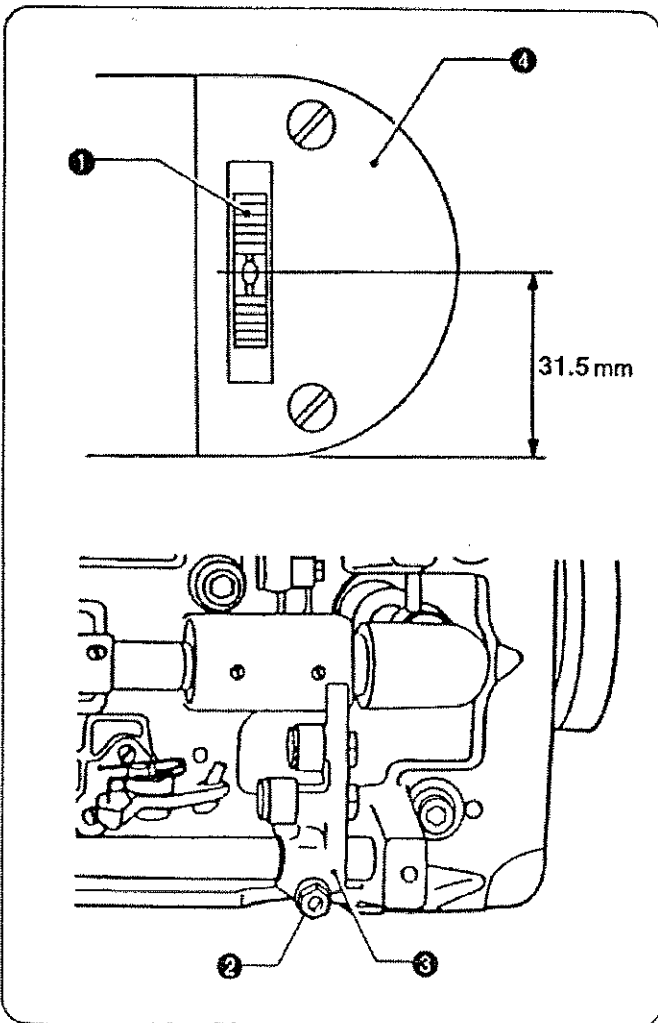

1. Change the feed amount to the smallest possible setting.
2. Turn the pulley to raise the feed dog ① to its highest position.
3. Tilt the machine head away from you.
4. Loosen the screw ②, and then move the feed rock shaft crank ③ to adjust so that there is a distance of 31.5mm from the edge of the needle plate ④ to the center of the needle hole on the feed dog ①.
5. Securely tighten the screw ②.

8-4. Adjusting the Positions of the needle and needle hole of the feed dog

Turning the pulley to lower the needle bar ① slowly, check whether the needle descends to the center of the needle hole of the feed dog or not.

If the needle does not enter into the center of the hole:

1. Remove the cover and loosen the screw ② slightly.
2. Holding the needle bar rock frame ③, move it as may be required to get the correct position to the feeder.
3. Tighten the screw ② and close the cover.

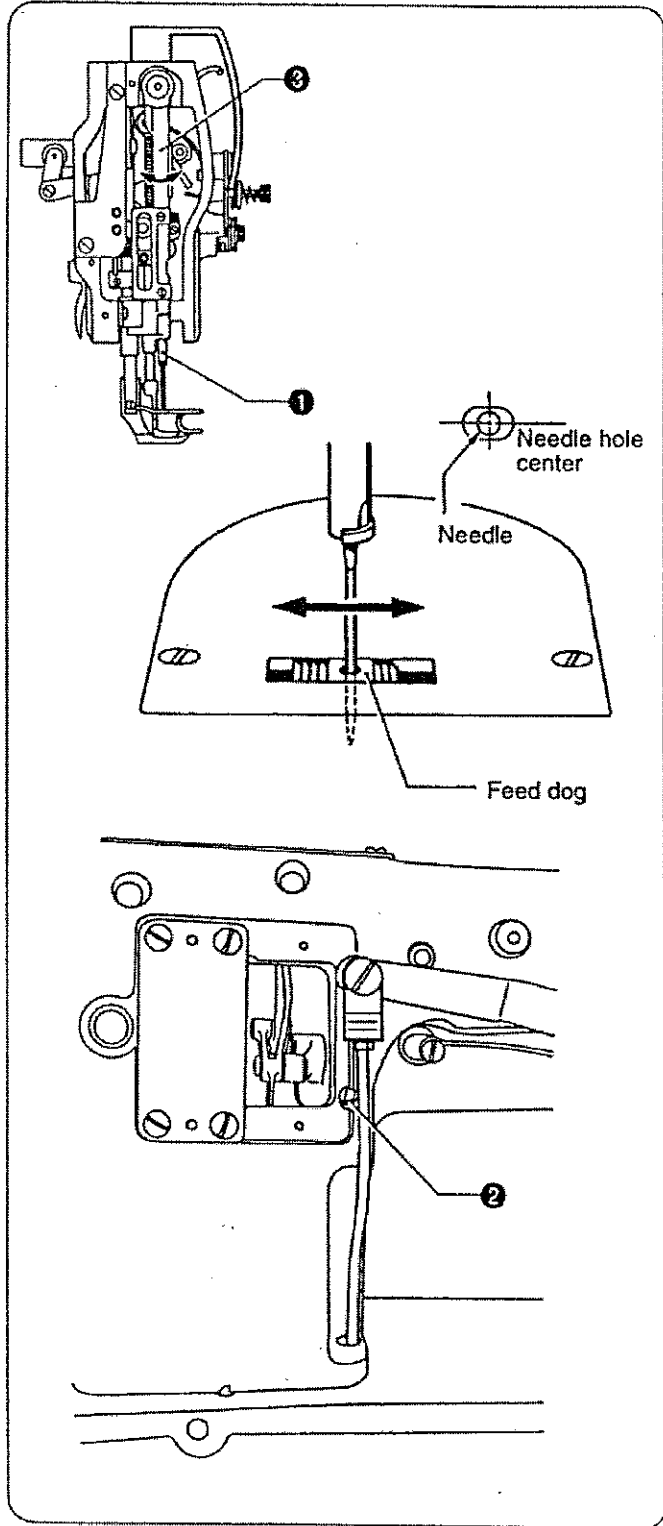

8-5. Adjusting the timing the needle with feed

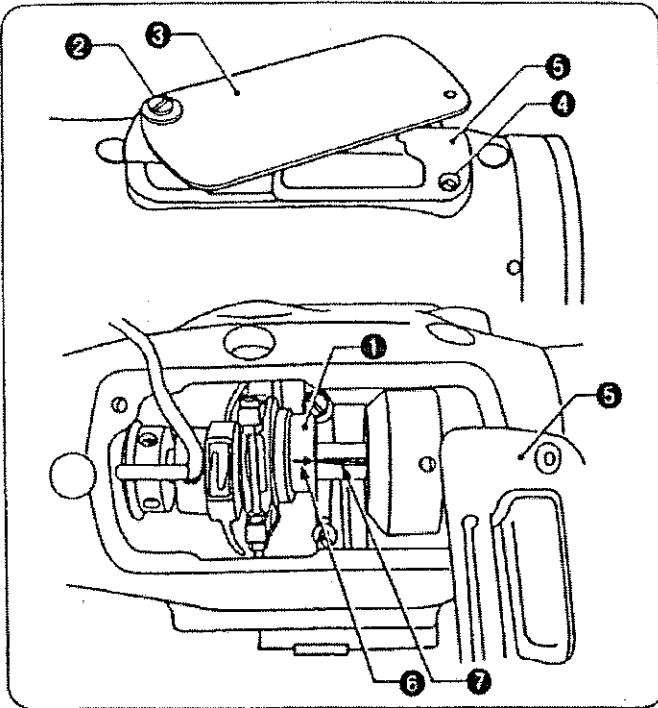

It is important that the timing relationship between the needle on its downward stroke and the feed dog movement is maintained at all times. When the start of the needle on the downward stroke reaches the top surface of the feed dog, the feed dog movement must start. When adjustment is required, use the following procedure to change the position of cam ①.

1. Change the feed amount to the largest possible setting.
2. Loosen the screw ② for cover plate ③ and the screw ④ for oil reservoir ⑤, and then remove the cover plate ③ and the oil reservoir ⑤.
3. Normally put the arrow mark ⑥ of the cam ① on the V ditch ⑦ of arm shaft.
4. Turn the machine pulley to the needle at 1 mm up from its lowest point.
5. And, pushing the reverse lever up and down, turn the cam ① and set this at the point both the needle and the feed dog rest.
6. After positioning completed, tighten the each screw securely.

8-6. Adjusting the height of the needle bar

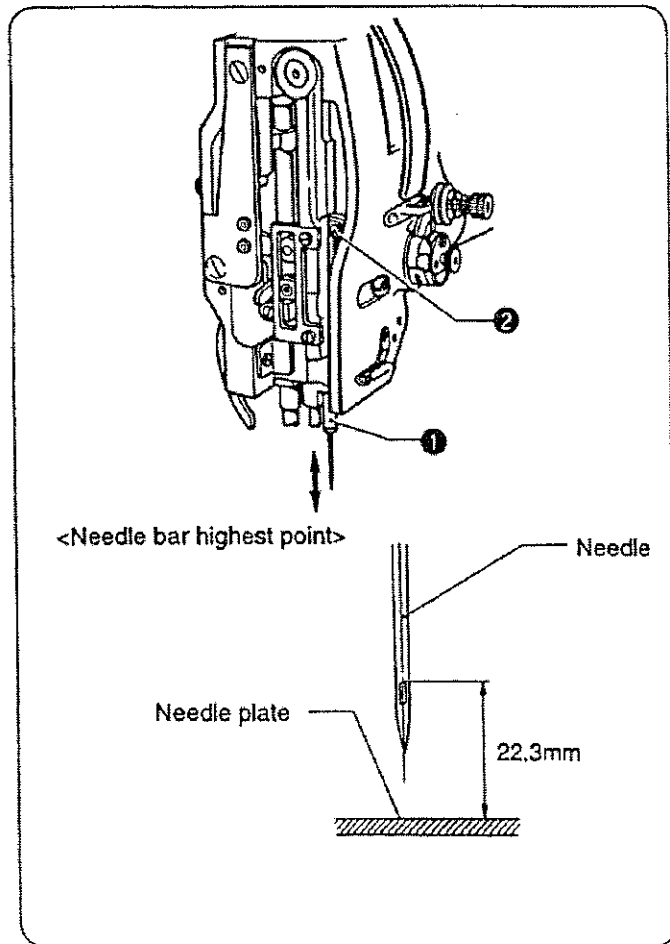

When the needle bar ① is at its highest point, normally the measurement between the surface of the needle plate and the upper end of the needle eye is 22.3mm.

1. Loosen the screw ② and move the setting position of the needle bar ① to get the correct position.
2. Tighten the screw ②.

8-7. Adjusting the timing between the needle and the hook

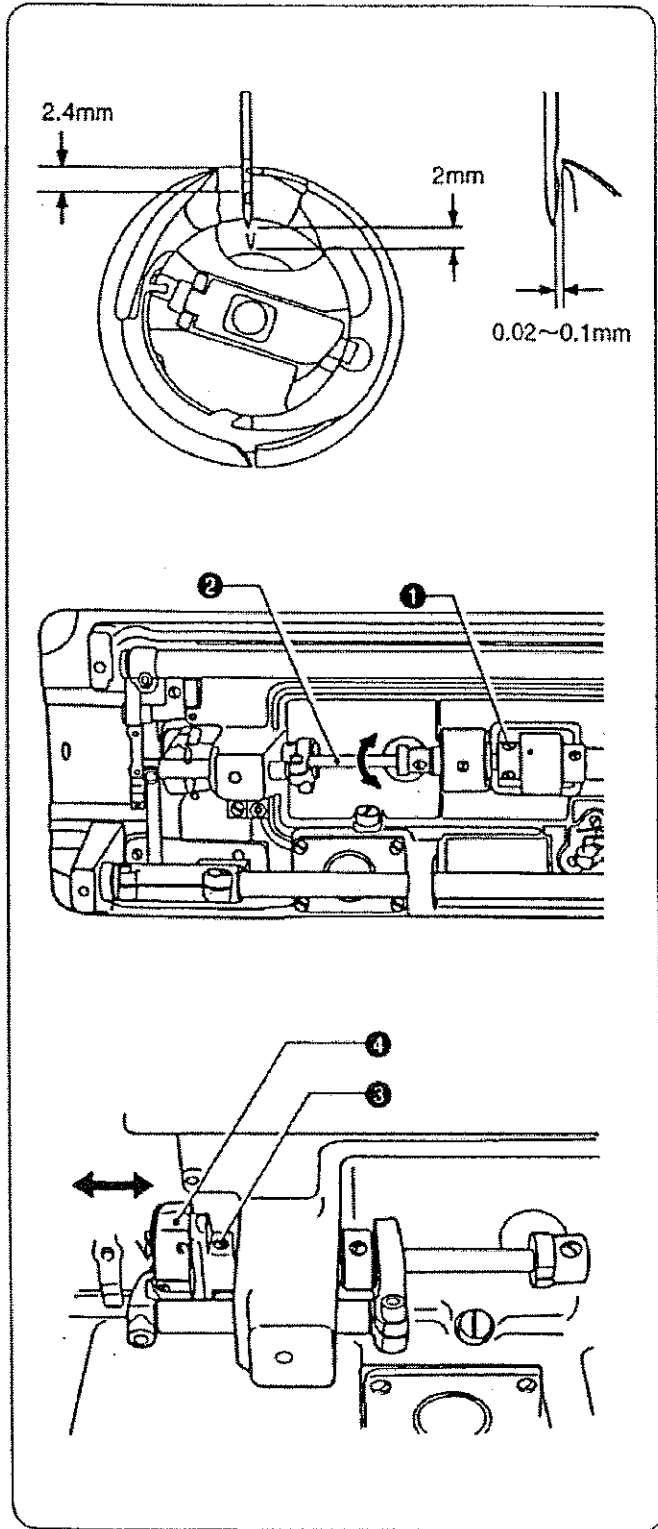

After setting the needle bar height, set stitch length to minimum, turn the machine pulley toward you until the needle bar reaches its lowest point. Continue turning and allow the needle bar to raise about 2mm while on its upward stroke. With needle bar in this position, the point of the sewing hook should be at the center of the needle, and normally, the measurement between the hook point and the upper end of the needle eye should be 2.4mm, further the clearance between the hook point and the needle hollow should be about 0.02 to 0.1mm.

* If they are not measured as above, perform the adjustments below.

■ Adjusting the timing

1. Loosen the three set screws ①.
2. Turn the hook shaft ② to align the hook point with the center of the needle.
3. Tighten the three set screws ① and re-check the timing of the sewing hook.

■ Adjusting the clearance

1. Loosen the two screws ③ slightly.
2. Move the hook ④ to the right or to the left as may require.
 - * Please note one of the two screws ③ is placed on the V ditch of hook shaft. Therefore, keep the screw on V ditch during adjustment.
3. Tighten the two screws ③.

8-8. Adjusting the Clearance between rotary hook and opener (Thread release finger)

The opener facilitates the passage of the needle thread loop by slightly nudging the inner hook creating a slight rotating movement of it. This movement at that very instant opens a clearance gap between the notch of the inner hook and the tab of the hook retainer permitting the needle thread loop to be drawn easily through the gap.

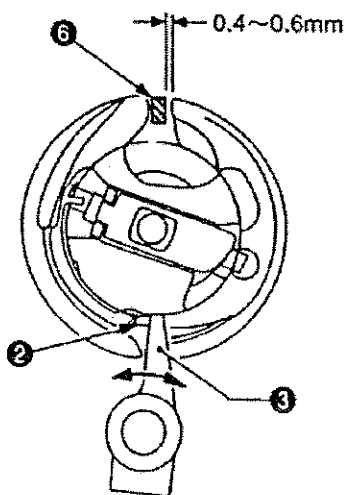
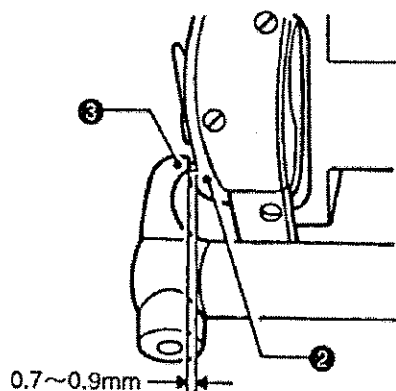
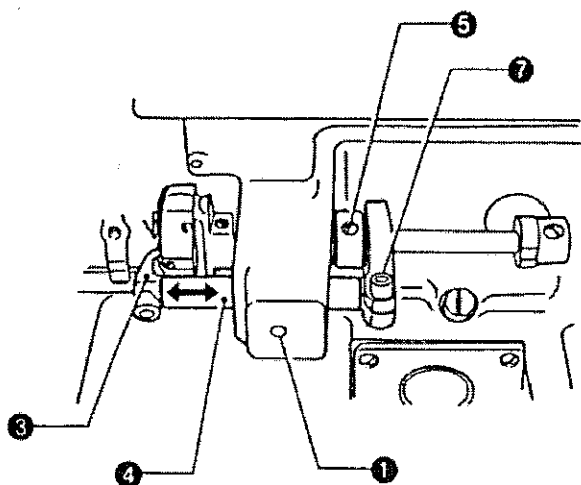

■ Clearance between the opener and projection of hook.

1. Loosen the screw ①.
2. Adjust the clearance between projection of hook ②, and the opener ③ by means of movement of thread releasing shaft bushing ④ to the right or to the left as may be required. The standard clearance between the two parts is 0.7-0.9mm.
3. Tighten the screw ① securely.

■ Position of the opener cam:

Place the one of screws ⑤ which is indicated by "S" on V ditch of the hook shaft.

■ Adjustment of operation:

1. Turn the machine pulley until the opener ③ presses the projection of hook ② extremely on its travel.
2. Press the opener ③ to the projection of hook ② and make the right side clearance between the notch on the bobbin case holder and tab the hook retainer ⑥ 0.4-0.6mm. This adjustment can be done by loosening the screw ⑦.
3. Tighten the screw ⑦ securely.

8-9. Adjusting the clearance between feed forked connection and feed fork collar

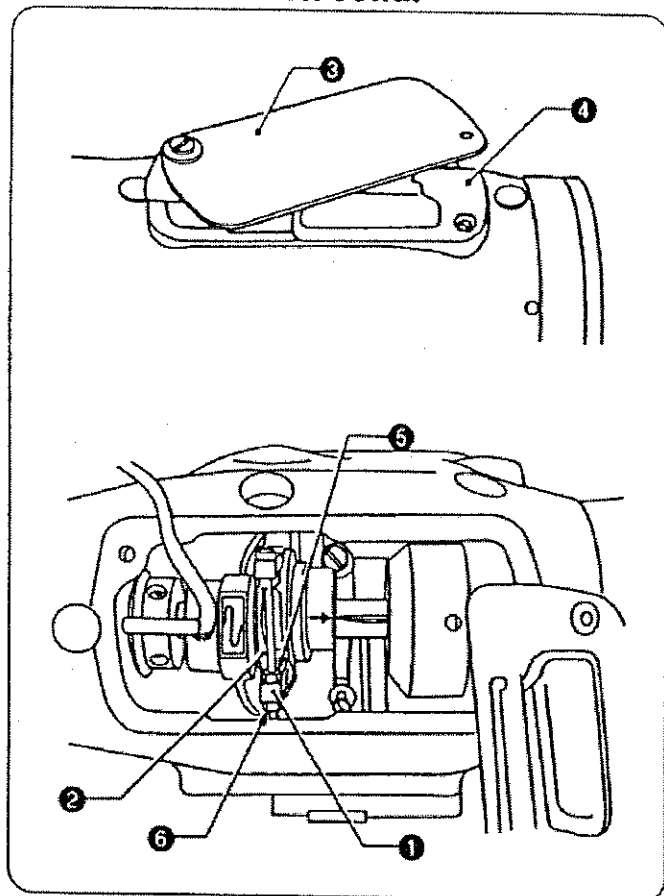

Incorrect clearance between the fork ① of feed forked connection and feed fork collar ② will bring irregular stitch length or overheating, etc.

1. Remove the cover plate ③ and the oil reservoir ④.
 2. To increase the clearance, loosen the nut ⑤ and turn the nut ⑥ to left or counter-clockwise.
- * This adjustment should be done with turning the machine pulley toward you to get correct clearance.
3. Upon completion of adjustment, tighten the screw ⑥ and screw ⑤.

8-10. Adjusting the height of the presser feet

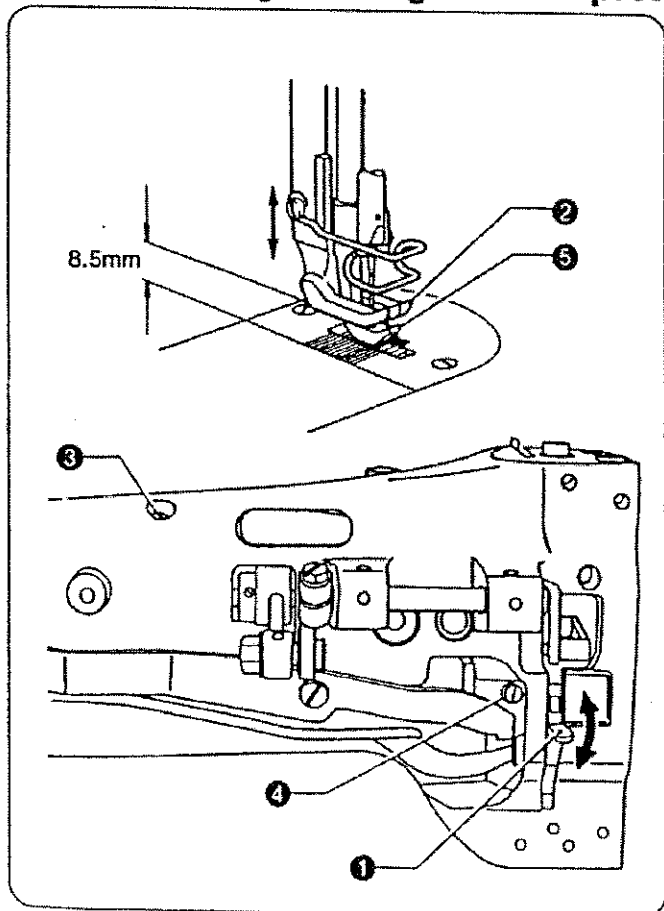

The standard height for the lifting presser foot ② is 8.5 mm when the presser foot has been raised by the presser bar lifter ①.

1. Loosen the screw ③, raise the presser bar lifter ①, and then loosen the set screw ④.
2. Move the lifting presser foot ② up or down to adjust its height.
3. Tighten the screw ④.
4. Tighten the screw ③ to adjust the presser foot pressure. (Refer to page 13.)

NOTE: If the height of the lifting presser foot ② is changed, the movement amount of the lifting presser foot ② and vibrating presser foot ⑤ will change. Adjust the amount of movement of the vibrating presser foot ⑤ so that it matches the movement of the lifting presser foot ②. (Refer to page 21.)

8-11. Adjusting the presser foot movement amount

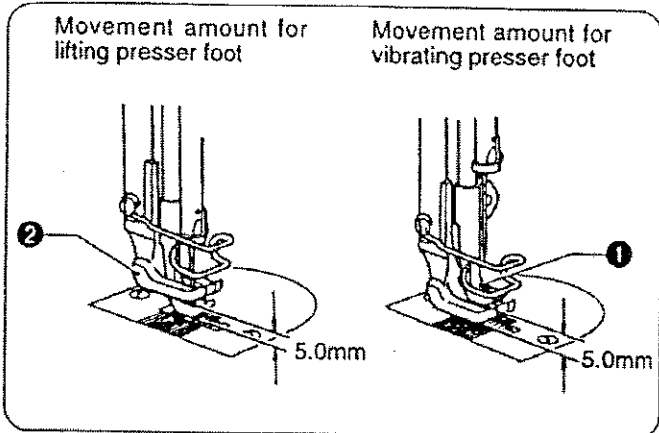

- Vibrating presser foot ① and lifting presser foot ② move up and down alternately.
- Normally, vibrating presser foot ① and lifting presser foot ② operate to the same height in their vertical motions.
- The maximum height of vibrating presser foot ① and lifting presser foot ② is 5.0 mm.

If changing the movement amounts of both the lifting presser foot and vibrating presser foot simultaneously, use method (A); if increasing the movement amount for only one (thereby decreasing the movement of the other), use method (B).

Method (A): Simultaneous adjustment of the movement amount for both the lifting presser foot and vibrating presser foot

1. Loosen nut ③.
2. Move nut ③ up or down as suitable to the work. (Raise the nut ③ for increasing motion; or lower it for decreasing motion.)
3. Tighten the nut ③.

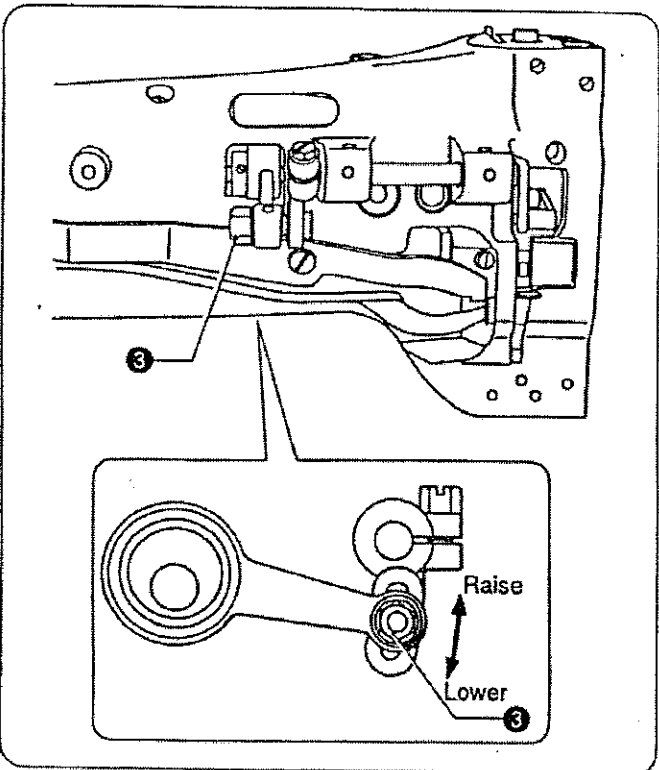

Method (B): Adjustment of the movement amount for the vibrating presser foot

1. Loosen the vibrating presser bar screw ④ and lower the presser bar lifter ⑤.
2. While holding the vibrating presser foot ①, loosen the bolt ⑥ and then move the presser foot ① up or down as necessary.
3. After positioning the vibrating presser foot ①, tighten the bolt ⑥.
4. Tighten the vibrating presser bar screw ④.

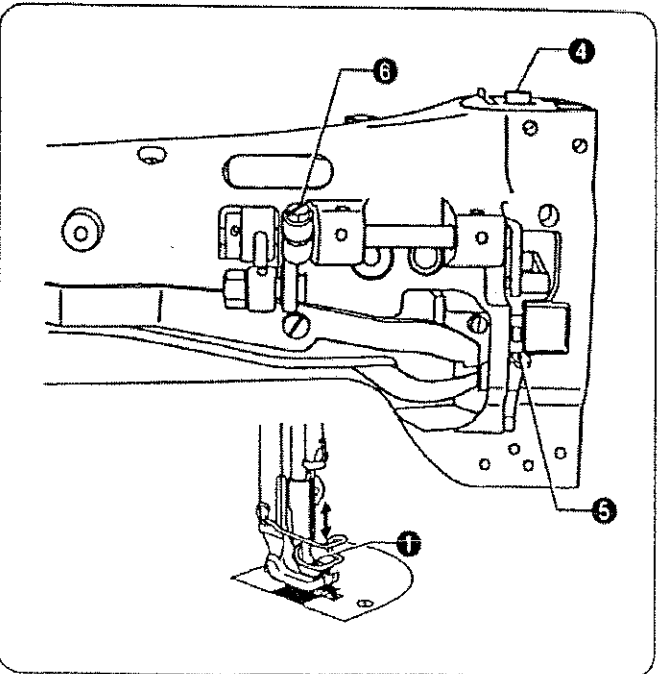

8-12. Adjusting the timing of the vibrating presser foot

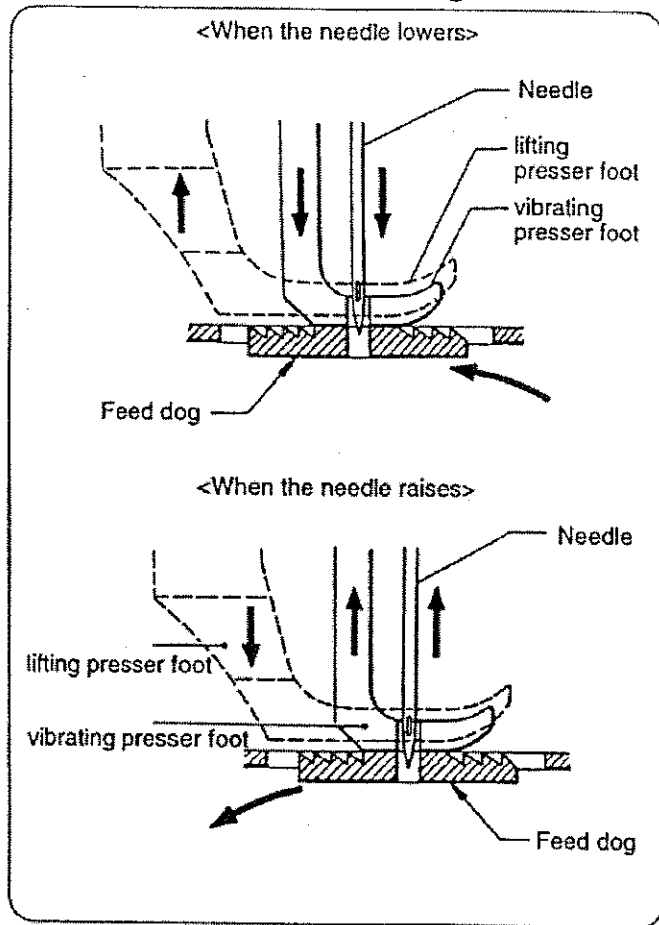

Check the vibrating presser foot timing as follows:

1. Lower the presser bar lifter lever, then turn the pulley toward you. At this time, the vibrating presser foot should reach the feed dog before the needle eye does.
2. When the needle is raised, make sure the vibrating presser foot is still holding the material firmly. If the vibrating presser foot rises while the needle is still penetrating the material, it may cause skipped stitches, etc.

cause

If the timing is not correct after you make these adjustments:

1. Loosen the two screws ❶.
2. To synchronize the timing of the vibrating presser foot, turn the cam ❷.
3. Tighten the screws ❶.

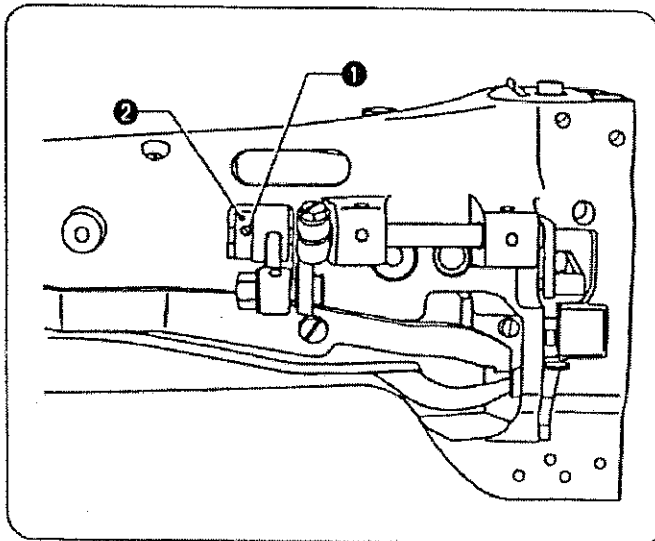

8-13. Adjusting the feed regulator

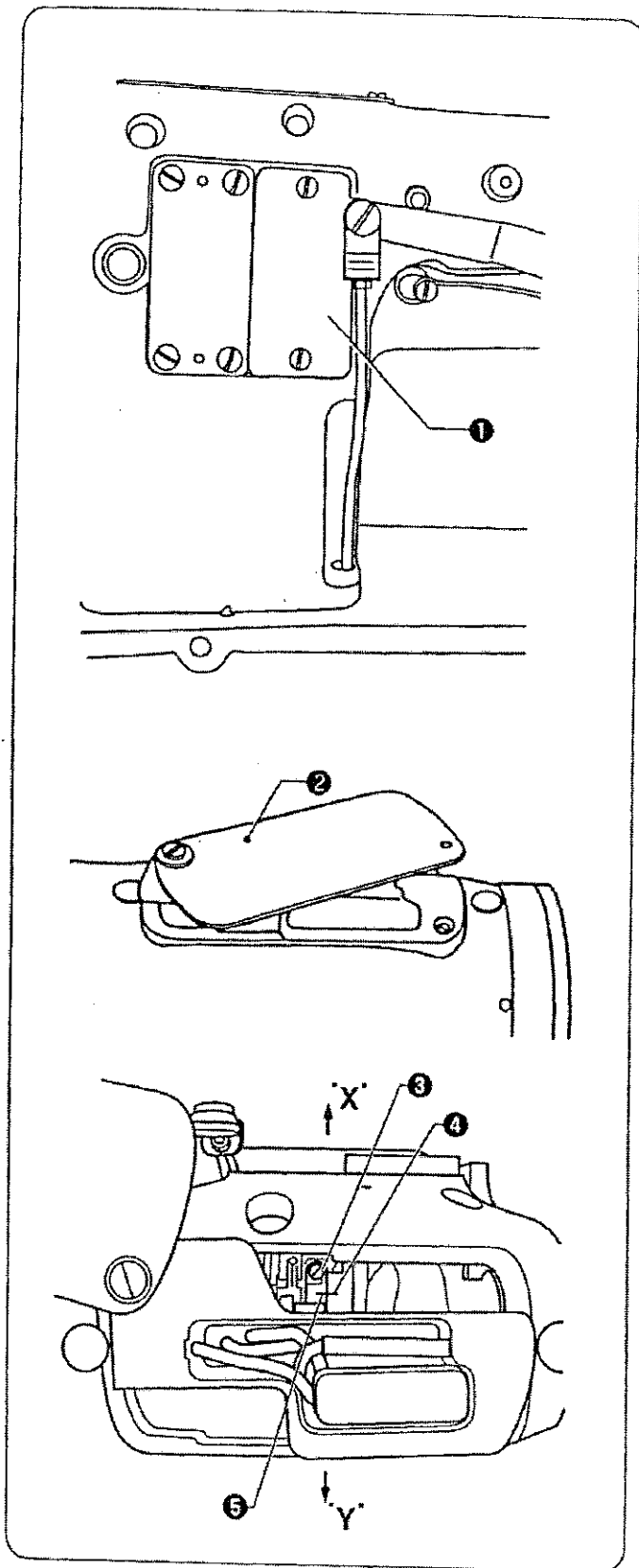

If the stitch length of forward and reverse are not same,make adjustment of feed regulator.

1. Remove the arm rear cover plate ❶ .
2. Turn the cover plate ❷ , loosen the screw ❸ with holding upward the reverse lever.
3. When the mark of feed regulator ❹ and feed regulator rod ❺ are alignment, stitch length of forward and reverse will be same.
4. Turn feed regulator rod ❺ to the arrow "X", stitch length of reverse is bigger and stitch length of forward is smoller.
5. Turn feed regulator rod ❺ to the arrow "Y",stitch length of reverse is smoller and stitch length of forward is bigger.
6. After adjustment,tigthen the screw ❸ .

9. SAFETY CLUCH MECHANISM

If the thread is tangled with the rotary hook during sewing, the safety clutch mechanism for the safety clutch pulley operates to stop the lower shaft and let the safety clutch pulley race off load, thereby protecting the rotary hook and timing belt.

Release the safety clutch mechanism as mentioned below.

■ Releasing the safety clutch mechanism

CAUTION



- Turn off the power switch before releasing the safety clutch mechanism. The motor will keep turning even after the power is switched off as a result of the motor's inertia. Wait until the motor stops fully before starting work. The machine may operate if the treadle is pressed by mistake, which could result in injury.

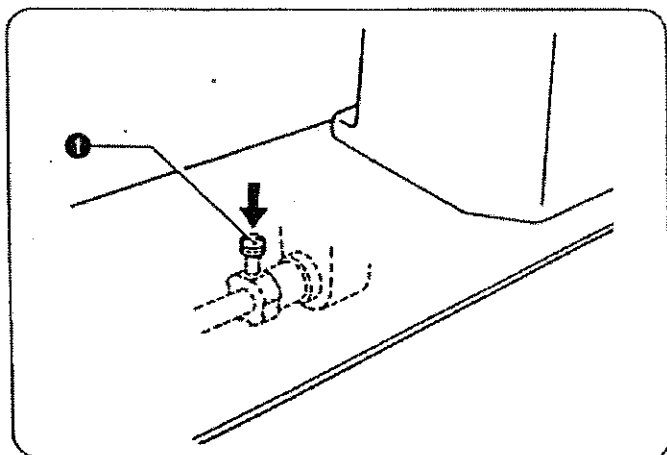

1. Remove the thread, etc. entangled with the rotary hook.

NOTE: Do not use a sharp-edged tool to clean the hook, as doing so may damage the hook.

2. Slowly turn the machine pulley while pressing push button ① and the safety clutch mechanism returns to the original position.

■ Adjustment of spring tension of safety clutch

If the safety clutch should become necessary to adjust spring tension, use the following procedure:

1. Depress the button ① in the bed plate of the machine with your left hand. At the same time, turn the machine pulley strongly so that the safety clutch disengages.
2. Tilt back the machine head. Hold the safety clutch (left) ② and turn the safety clutch (right) ③ until you can see the screw ④ through the hole ⑤.
3. To strengthen the tension of spring ⑥, turn the screw ④ to the right, while to lighten the tension, turn the screw ④ to the left.
4. Upon completion of adjustment, depress the button ①. At the same time, turn the machine pulley until the safety clutch re-engages.

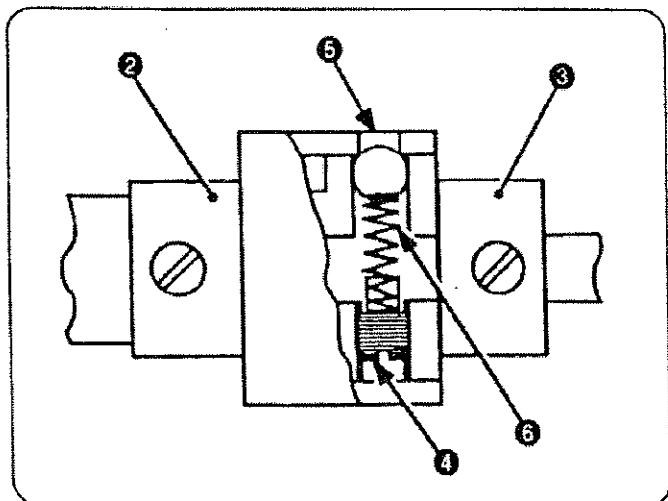

CONTENTS

FACE PLATE, NEEDLE PLATE, THREAD TENSION.....	1, 2
ARM SHAFT, THREAD TAKE-UP LEVER.....	3, 4
NEEDLE BAR, NEEDLE BAR ROCK FRAME.....	5, 6
PRESSER BAR, LIFTING PRESSER FOOT.....	7, 8
FEED MECHANISM.....	9, 10
FEED REGULATOR.....	11, 12
ARM SHAFT, LOWER SHAFT.....	13, 14
LUBRICATION.....	15, 16
ACCESSORIES.....	17, 18
PARTS AVAILABLE AT EXTRA CHARGE.....	19, 20

THREAD TENSION, NEEDLE PLATE

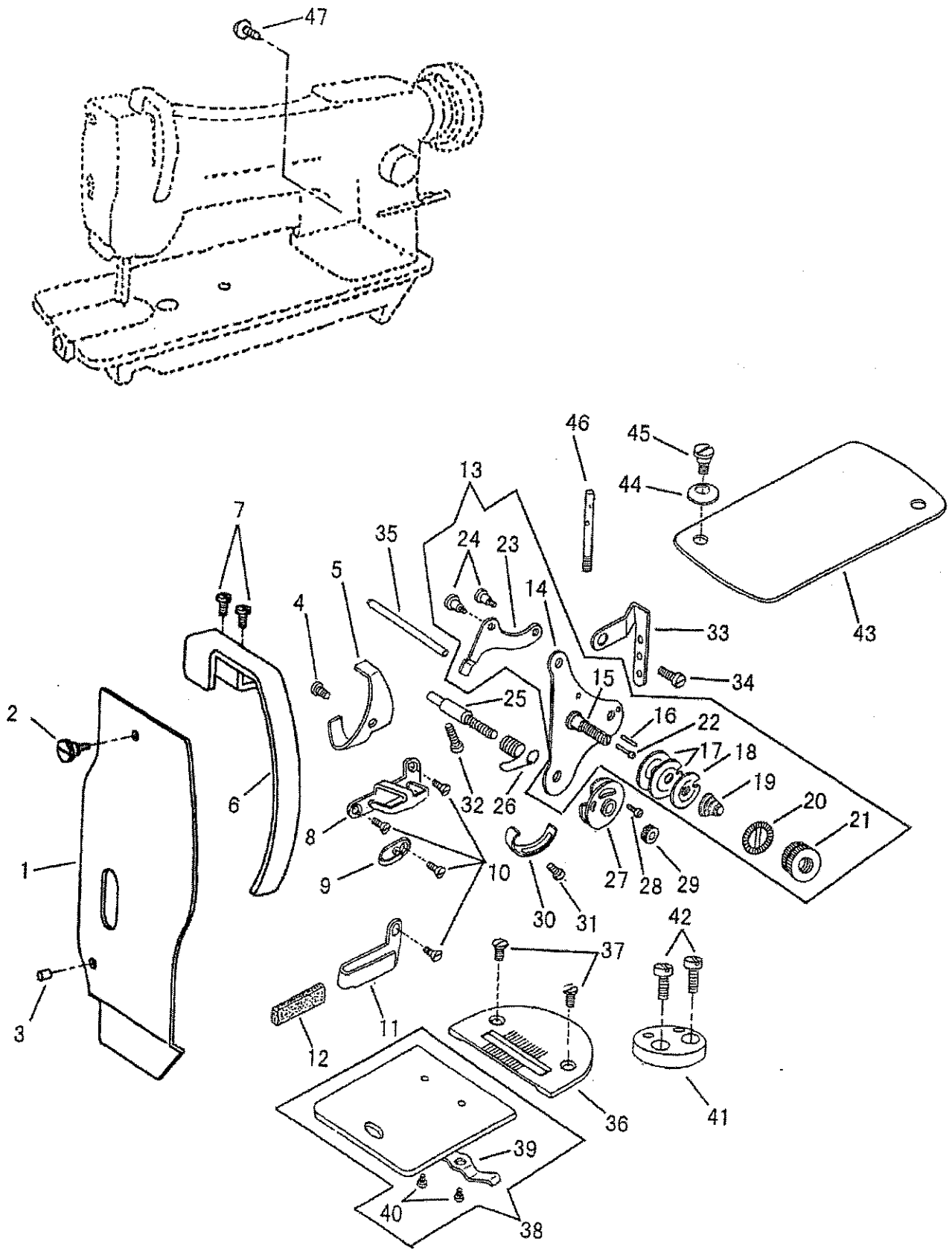

FACE PLATE, NEEDLE PLATE, THREAD TENSION

Description

	PARTS NO.	-3	-2	QTY		
1	19451	*		1	面板	FACE PLATE
2	8093	*	*	1	面板止めねじ	SCREW 9/64X40
3	10700	*	*	1	面板位置決めピン	POSITION PIN
4	3052	*		1	天秤油受止めねじ	SCREW 9/64X40 L=4.5
5	10551	*	*	1	天秤油受	OIL GUARD
6	19452	*		1	天秤カバー	TAKE-UP LEVER COVER
7	8040	*		2	天秤カバー止めねじ	SCREW 9/64X40 L=8.0
8	15054	*		1	面糸掛(上)	THREAD GUIDE (UPPER)
9	10683	*	*	1	面糸掛(中)	THREAD GUIDE (MIDDLE)
10	19510	*	*	4	面糸掛止めねじ	SCREW 9/64X40 L=6.5
11	10759-A	*	*	1	面糸掛(下)	THREAD GUIDE (LOWER)
12	10760	*	*	1	面糸掛フェルト	THREAD GUIDE FELT
13	19421C-A	*	*	1	調子板(組)	TENSION BRACKET COMPLETE
14	19421	*	*	1	調子板	TENSION BRACKET
15	19511	*	*	1	糸調子棒	TENSION STUD
16	10791	*	*	1	調子板ピン	TENSION BRACKET PIN
17	19531	*	*	2	調子皿	THREAD DISC
18	19532	*	*	1	丸一皿	TENSION RELEASE WASHER
19	19533	*	*	1	渦巻スプリング	TENSION SPRING
20	28206	*	*	1	ローレットストッパー	TENSION THUMB NUT STOPPER
21	19513	*	*	1	ローレットナット	TENSION THUMB NUT
22	10793	*	*	1	糸ゆるめ段ピン	TENSION RELEASE PLUNGER
23	10678	*	*	1	糸ゆるめ板	TENSION RELEASE LEVER
24	19422	*	*	2	糸ゆるめ板段ねじ	SCREW 9/64X40
25	19512	*	*	1	糸調子棒	THREAD CONTROLLER STUD
26	10689	*	*	1	糸引きスプリング	THREAD CONTROLLER SPRING
27	10694	*	*	1	二重皿	THREAD CONTROLLER DISC
28	B118319	*	*	1	二重皿止めねじ	SCREW 3/32X56 L=6.0
29	19534	*	*	1	ローレットナット	TENSION THUMB NUT
30	10690	*	*	1	スプリング受	THREAD CONTROLLER SPRING STOP
31	8100	*	*	1	スプリング受止めねじ	SCREW 9/64X40 L=6.5
32	19518	*	*	1	糸調子棒止めねじ	SCREW 11/64X40 L=14.0
33	15062	*	*	1	大糸掛	THREAD RETAINER
34	18085	*	*	1	調子板止めねじ	SCREW 11/64X40 L=8.5
35	19501	*		1	糸ゆるめピン	TENSION RELEASE LEVER ROD
36	18030-S	*	*	1	針板	NEEDLE PLATE
37	6031-02	*		2	針板止めねじ	SCREW 11/64X40 L=8.5
38	18032C	*	*	1	角板(組)	BED SLIDE COMPLETE
39	6034	*	*	1	角板裏ばね	BED SLIDE SPRING
40	6035	*	*	2	角板裏ばね止めねじ	SCREW 3/32X56 L=2.7
41	18495	*	*	1	定規止板	EDGE GUIDE PLATE
42	37254	*	*	2	定規止板止めねじ	SCREW M4X0.7 L=8.0
43	19455	*		1	上板	ARM CAP
44	10703	*	*	1	上板止ワッシャー	WASHER
45	12384	*	*	1	上板段ねじ	SCREW 3/16X32
46	10709	*	*	1	糸立棒	SPOOL PIN SCREW 7/32X32
47	30046	*	*	1	アース線止めねじ	EARTH WIRE SCREW M4X0.7 L=4.0

ARM SHAFT, TAKE UP LEVER

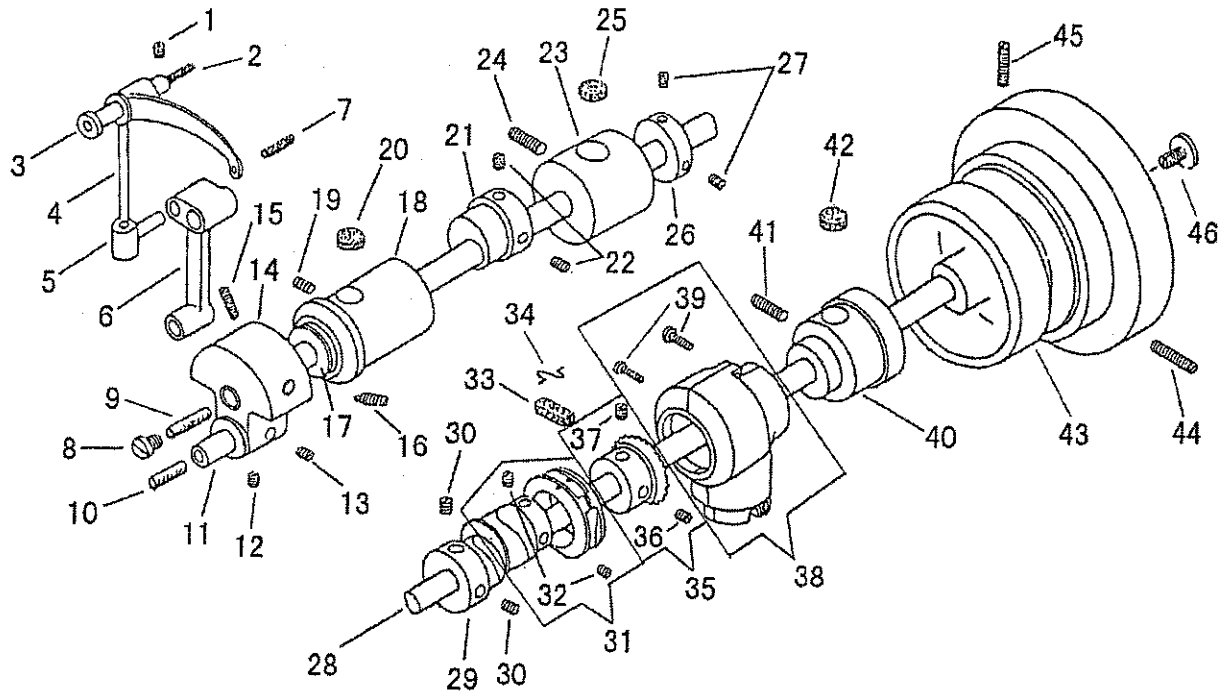

ARM SHAFT, THREAD TAKE-UP LEVER

Description

	PARTS NO.	-3	-2	QTY		
1	8009	*		1	天秤ピン止めねじ	SCREW 15/64X28 L=7.5
2	10724	*		1	天秤ピン油芯 6 X 6 X 180	OILING WICK
3	10527	*	*	1	天秤ピン	TAKE-UP LEVER HINGED STUD
4	18003	*	*	1	天秤	THREAD TAKE-UP LEVER
5	15026	*	*	1	天秤抱き	TAKE-UP LEVER DRIVING STUD
6	10528	*	*	1	針棒クランク	NEEDLE BAR CONNECTING LINK
7	10728	*	*	1	天秤抱き油芯 6 X 6 X 25	OILING WICK
8	19504	*	*	1	上軸油栓ねじ	OIL PACKING STOP SCREW 5/16X28 L=6.0
9	10724	*	*	1	上軸油芯 6 X 6 X 180	OILING WICK
10	10726	*	*	1	針棒クランクピン油芯 6 X 6 X 50	OILING WICK
11	10523	*	*	1	針棒クランクピン	NEEDLE BAR CONNECTING LINK STUD
12	19418	*	*	1	針棒クランクピン止めねじ(短)	SCREW 1/4X28 L=4.5
13	19417	*	*	1	針棒クランクピン止めねじ(長)	SCREW 1/4X28 L=6.5
14	19414	*	*	1	クランクモーシオンカム	NEEDLE BAR CRANK
15	19416	*	*	1	止めねじ	SET SCREW 1/4X28 L=14.0
16	19415	*	*	1	位置決めめじ	POSITION SCREW 1/4X28 L=20.0
17	10563	*	*	1	上軸メタル(前)ワッシャー	WASHER
18	18006	*	*	1	上軸メタル(前)	ARM SHAFT BUSHING (FRONT)
19	1786	*	*	1	上軸メタル(前)止めねじ	SCREW 15/64X28 L=12.0
20	10725	*	*	1	上軸メタル(前)フェルト	OILING FELT
21	18486	*		1	中押え上下カム	LIFTING ECCENTRIC
22	19508	*	*	2	中押え上下カム止めねじ	SCREW 1/4X40 L=5.5
23	18008	*	*	1	上軸メタル(中間)	ARM SHAFT BUSHING (MIDDLE)
24	10579	*	*	1	上軸メタル(中間)止めねじ	SCREW 15/64X28 L=20.0
25	10725	*	*	1	上軸メタル(中間)フェルト	OILING FELT
26	19506	*	*	1	上軸カラー	ARM SHAFT BUSHING COLLAR
27	23637	*	*	2	上軸カラー止めねじ	SCREW 1/4X28 L=7.5
28	19503	*		1	上軸	ARM SHAFT
29	19521	*	*	1	送り上下カム	FEED LIFTING CAM
30	10827	*		2	送り上下カム止めねじ	SCREW 1/4X40 L=7.5
31	19526C	*	*	1	送りカム(組)	FEED DRIVING ECCENTRIC COMPLETE
32	23637	*	*	2	送りカム止めねじ	SCREW 1/4X28 L=7.5
33	17041	*	*	1	二又リンクフェルト	OILING FELT
34	10723	*	*	1	二又リンクフェルト押え	OILING FELT RETAINER
35	17017C	*	*	1	上軸ギヤーねじ付	ARM SHAFT GEAR (SPIRAL) COMPLETE
36	17018	*	*	1	位置決めねじ	POSITION SCREW 1/4X40 L=8.0
37	17019	*	*	1	止めねじ	SET SCREW 1/4X40 L=7.5
38	17015C	*	*	1	ギヤーカバーセット(上)	GEAR COVER COMPLETE (UPPER)
39	17016	*	*	2	ギヤーカバー(上)締めねじ	SET SCREW 9/64X40 L=10.0
40	17013	*	*	1	上軸メタル(後)	ARM SHAFT BUSHING (REAR)
41	10579	*	*	1	上軸メタル(後)止めねじ	SCREW 15/64X28 L=20.0
42	13081	*	*	1	上軸メタル(後)フェルト	OILING FELT
43	18470	*	*	1	プーリー	BALANCE WHEEL
44	10576	*	*	1	位置決めねじ	POSITION SCREW 15/64X28 L=21.0
45	10579	*	*	1	止めねじ	SET SCREW 15/64X28 L=20.0
46	19505	*	*	1	プーリー押しねじ	SCREW 3/32X28 L=11.0

NEEDLE BAR, FEEDING MECHANISM

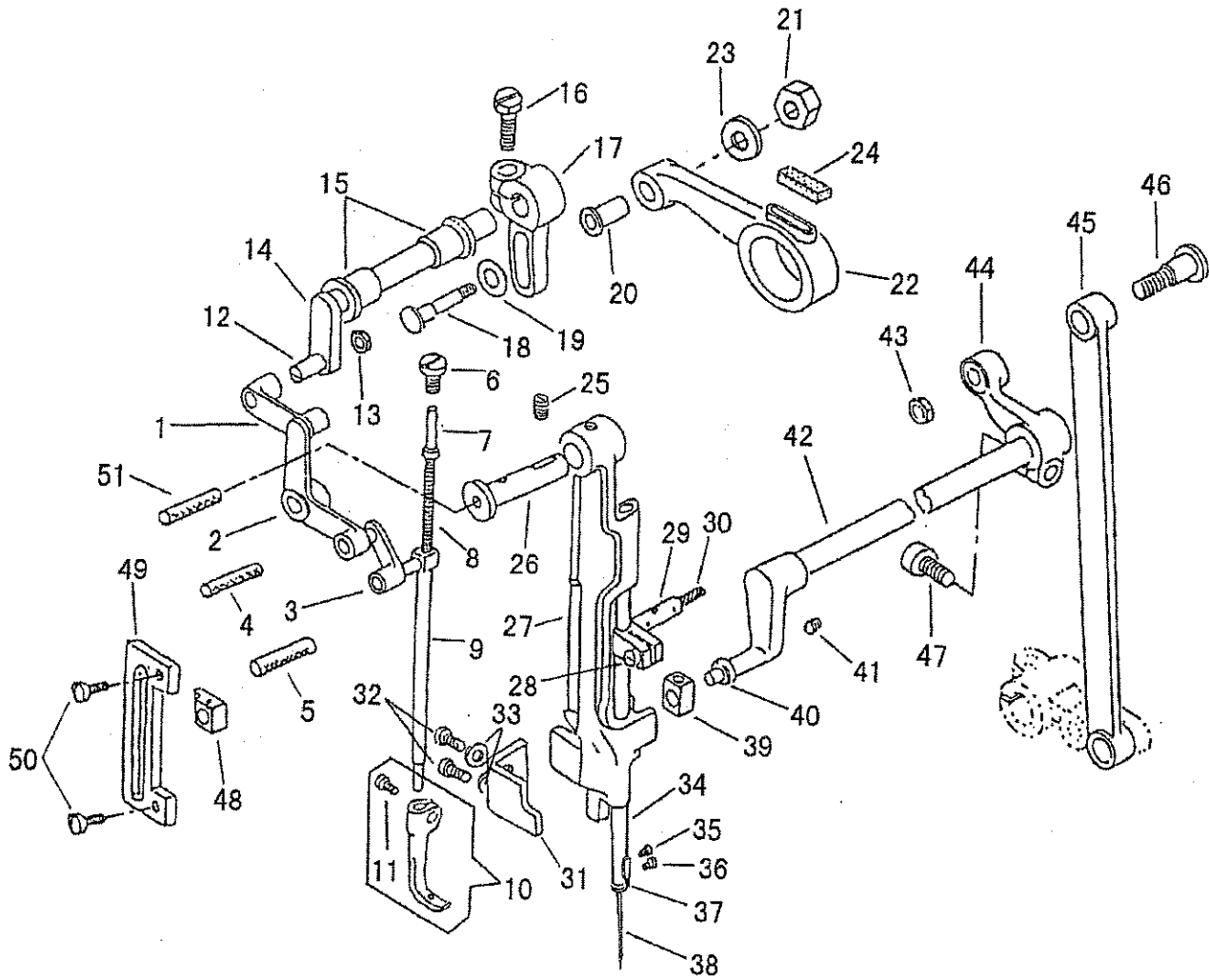

NEEDLE BAR, NEEDLE BAR ROCK FRAME

Description

	PARTS NO.	-3	-2			
1	10557	*	*	1	くの字連結(大)	LIFTING BELL CRANK LINK
2	19509	*		1	くの字	LIFTING BELL CRANK
3	10556	*	*	1	くの字連結(小)	PRESSER BAR CONNECTING LINK
4	10728	*		1	くの字連結(小)油芯 6 X 6 X 25	OILING WICK
5	10728	*	*	1	中押え棒油芯 6 X 6 X 25	OILING WICK
6	19517	*	*	1	中押え棒押しねじ	SCREW 5/16X28 L=16.0
7	10553-A	*	*	1	中押えスプリング棒	VIBRATING PRESSER BAR EXTENSION
8	10554	*	*	1	中押えスプリング	PRESSER BAR EXTENSION SPRING
9	34713	*	*	1	中押え棒	VIBRATING PRESSER BAR
10	194120	*	*	1	中押え(溝付)(ねじ付)組	VIBRATING PRESSER FOOT COMPLETE
11	17104	*	*	1	中押え締ねじ	PINCH SCREW 11/64X40 L=6.0
12	19515	*	*	1	横軸ピンねじ	HINGE SCREW 1/4X28
13	19516	*	*	1	横軸ピンねじナット	NUT 1/4X28
14	19514	*		1	横軸	LIFTING ROCK SHAFT
15	10514	*	*	2	横軸メタル	LIFTING ROCK SHAFT BUSHING
16	19420	*	*	1	上下カム連結だるま締ねじ	PINCH SCREW 1/4X28 L=16.0
17	19419	*	*	1	上下カム連結だるま	CONNECTING CRANK
18	10775	*	*	1	上連結ロッド段ねじ	HINGE SCREW 7/32X32
19	12136	*		1	上連結ロッド段ねじワッシャー	WASHER
20	10774	*	*	1	上連結ロッドパイプ	CONNECTING COLLAR
21	17114	*		1	上連結ロッド段ねじナット	NUT 7/32X32
22	18485	*		1	上連結ロッド	LIFTING ECCENTRIC CONNECTION
23	37215	*		1	上連結ロッド段ねじナットワッシャー	WASHER
24	17041	*		1	上連結ロッドフェルト	OILING FELT
25	100446	*	*	1	針棒土台ピン止めねじ	SCREW 15/64X28 L=8.8
26	34712	*		1	針棒土台ピン	HINGE STUD
27	17611	*		1	針棒土台	NEEDLE BAR ROCK FRAME
28	37134	*		1	針棒抱き締ねじ	PINCH SCREW M4X0.7 L=10.0
29	19426	*	*	1	針棒抱き	NEEDLE BAR CONNECTING STUD
30	19429	*		1	針棒抱き油芯 12 X 12 X 30	OILING WICK
31	34723	*		1	イケール	POSITION BRACKET
32	37134	*		2	イケール止めねじ	SCREW M4X0.7 L=10.0
33	30078	*		2	イケール止ワッシャ	WASHER
34	19413	*	*	1	針棒	NEEDLE BAR
35	6035	*		1	針棒糸掛け止めねじ	SCREW 3/32X56 L=2.7
36	B140553	*	*	1	針止めねじ	SCREW 1/8X40 L=4.5
37	10533	*	*	1	針棒糸掛	NEEDLE BAR THREAD GUIDE
38	N0122	*	*	1	針 DPX17 #22	NEEDLE DPX17 #22
39	11877	*	*	1	上送り竿角玉	SLIDE BLOCK
40	11876	*	*	1	上送り竿ピンねじ	HINGE SCREW 7/32X32
41	10581	*	*	1	上送り竿ピンねじ止めねじ	SCREW 7/32X32 L=7.0
42	17048	*	*	1	上送り竿	NEEDLE BAR ROCK FRAME ROCK SHAFT
43	6026-02	*	*	1	連結ロッド段ねじナット	NUT 9/32X28
44	19409	*	*	1	連結	CONNECTION
45	18017	*	*	1	連結ロッド	CONNECTION ROD
46	18018	*	*	1	連結ロッド段ねじ	HINGE SCREW 9/32X28
47	19408	*	*	1	連結締ねじ	PINCH SCREW 1/4X28 L=17.5
48	34722	*		1	振れ止角玉	VIBRATING PRESSER BAR BLOCK
49	34721	*		1	振れ止板	VIBRATING PRESSER BAR BLOCK GUIDE
50	8100	*	*	2	振れ止板止めねじ	SCREW 9/64X40 L=6.5
51	10728	*		1	針棒土台ピン油芯 6 X 6 X 25	OILING WICK

PRESSER BAR

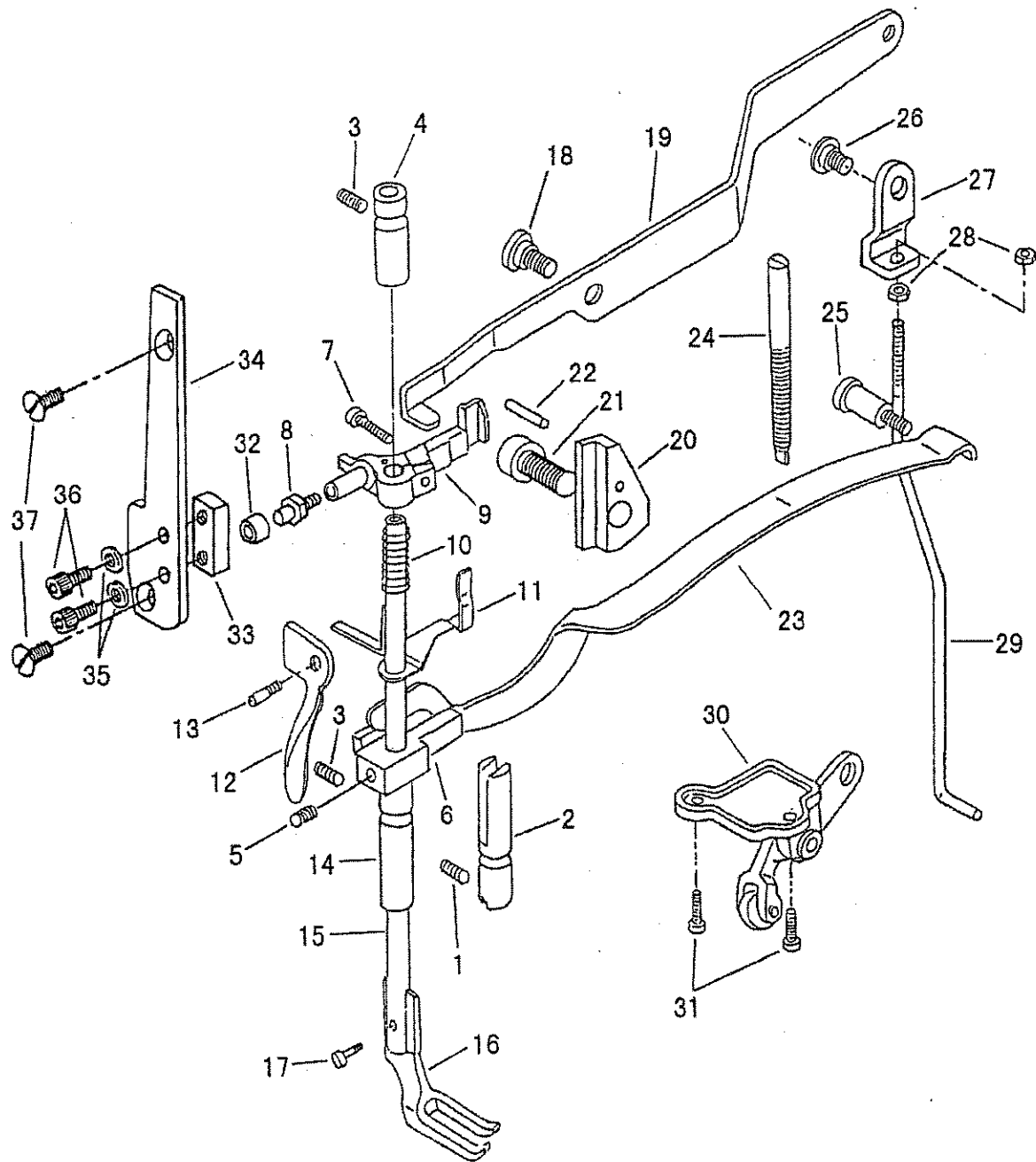

PRESSER BAR, LIFTING PRESSER FOOT

				Description	
	PARTS NO.	-3	-2		
1	28043	*		1	案内棒止めねじ SCREW M6X1 L=10.0
2	36729	*		1	案内棒 PRESSER BAR POSITION GUIDE
3	19406	*	*	2	押え棒メタル止めねじ SCREW 15/64X28 L=11.0
4	10538	*	*	1	押え棒メタル(上) PRESSER BAR BUSHING (UPPER)
5	35999	*		1	押え棒案内締ねじ SCREW M6X1 L=6.0
6	18478	*		1	押え棒案内 PRESSER BAR POSITION GUIDE BRACKET
7	19518	*	*	1	押え棒抱き締ねじ PINCH SCREW 11/64X40 L=14.0
8	34828	*		1	くの字案内ピンねじ SCREW 11/64X40
9	18479	*	*	1	押え棒抱き PRESSER BAR LIFTING BRACKET
10	10547	*	*	1	押え棒抱き下板ばね SPRING
11	10546-A	*	*	1	押え棒抱き下板 TENSION RELEASE SLIDE
12	10659	*	*	1	押え上げレバー PRESSER BAR LIFTER
13	19405	*	*	1	レバーピンねじ HINGE SCREW 3/16X32
14	18085	*	*	2	大砲止めねじ SCREW 11/64X40 L=8.5
15	18477	*		1	押え棒 PRESSER BAR
16	10796	*	*	1	外押え LIFTING PRESSER FOOT
17	18483	*		1	外押え止めねじ SCREW 9/64X40 L=9.0
18	19403	*	*	1	弓止めねじ HINGE SCREW 1/4X28
19	18080	*	*	1	弓 KNEE LIFTER LIFTING LEVER
20	10548-A	*	*	1	押え棒抱き振れ止台 BRACKET GUIDE BLOCK
21	19408	*	*	1	振れ止台止めねじ PINCH SCREW 1/4X28 L=17.5
22	15111	*	*	1	振れ止台ピン PIN
23	36026	*		1	押え棒大板ばね PRESSER BAR SPRING
24	19519	*	*	1	大板ばね調節ねじ PRESSER BAR SPRING REGULATING SCREW 1/4X28
25	19404	*	*	1	大板ばね受ねじ PRESSER BAR SPRING SUPPORT SCREW 1/4X28
26	6384	*	*	1	吊り棒たるま段ねじ HINGE SCREW 15/64X28
27	6359-A	*	*	1	吊り棒たるま LIFTING LEVER CONNECTING ROD JOINT
28	6360	*	*	2	吊り棒ナット NUT 3/16X32
29	18081	*	*	1	吊り棒 LIFTING LEVER CONNECTING ROD
30	18862	*	*	1	大砲セット KNEE LIFTER BELL CRANK COMPLETE
31	10539-A	*		1	押え棒メタル(下) PRESSER BAR BUSHING (LOWER)
32	34717	*		1	くの字案内カラー LIFTING BELL CRANK GUIDE COLLAR
33	34718	*		1	くの字案内駒 LIFTING BELL CRANK GUIDE BLOCK
34	34719	*		1	くの字案内板 LIFTING BELL CRANK GUIDE PLATE
35	16287	*		2	くの字案内駒止ワッシャー WASHER
36	30601	*		2	くの字案内駒止めねじ SCREW M5X0.8 L=10.0
37	34720	*		2	くの字案内板止めねじ SCREW M6X1 L=12.0

LOWER FEEDING MECHANISM

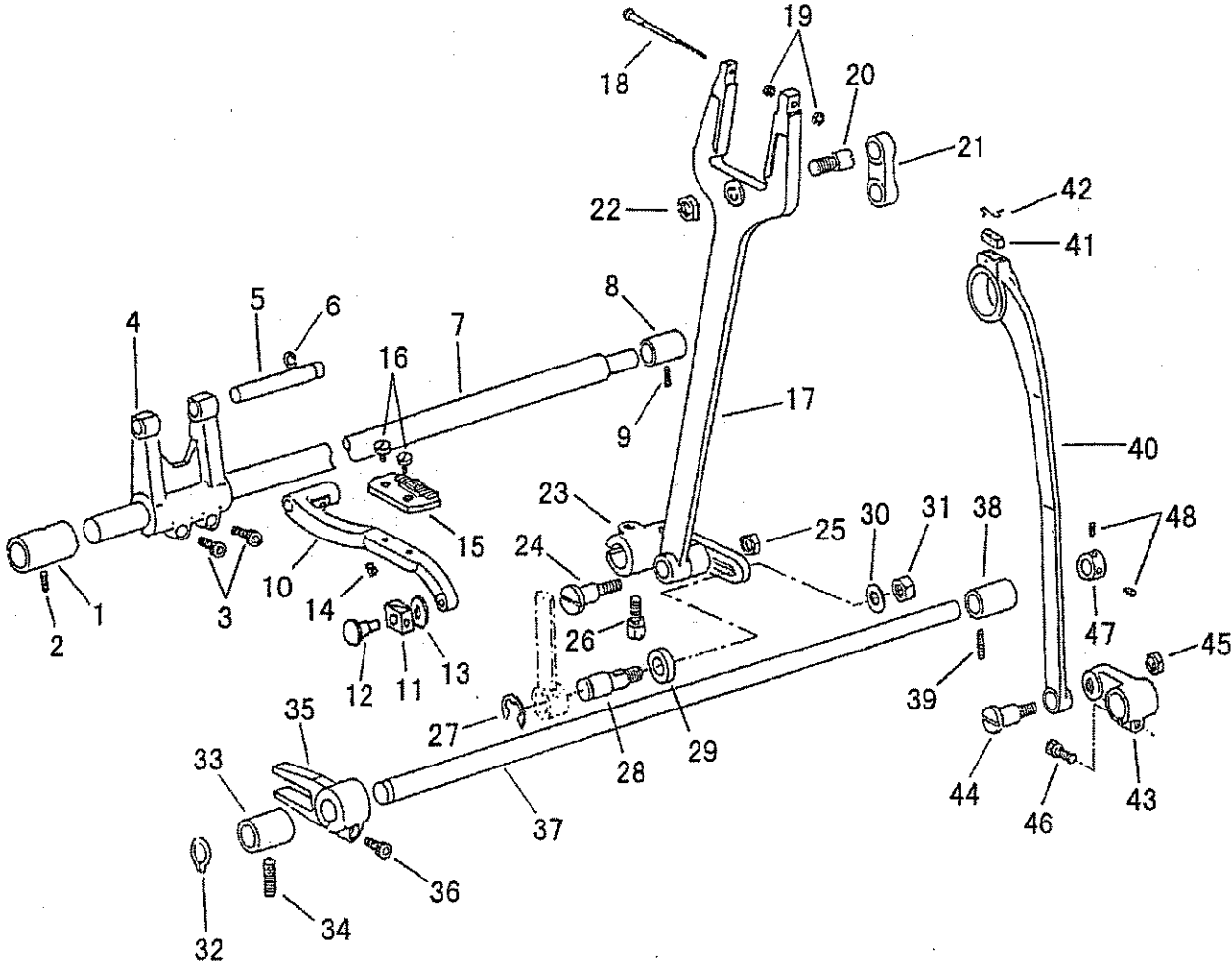

FEED MECHANISM

PARTS NO.				Description		
	-3	-2				
1	18523	*	*	1	送り軸メタル(前)	FEED ROCK SHAFT BUSHING (FRONT)
2	8009	*	*	1	止めねじ	SCREW 15/64X28 L=7.5
3	18065	*	*	2	送り腕締ねじ	PINCH SCREW M5X0.8 L=14.0
4	18694	*	*	1	送り腕	FEED ROCK SHAFT BASE
5	18696	*	*	1	送り土台受ピン	FEED BASE SUPPORTING PIN
6	31094	*	*	1	送り土台受ピン止め輪	"E" RING
7	18061	*	*	1	送り軸	FEED ROCK SHAFT
8	18702	*	*	1	送り軸メタル(後)	FEED ROCK SHAFT BUSHING (BACK)
9	8009	*	*	1	止めねじ	SCREW 15/64X28 L=7.5
10	19526	*	*	1	送り土台	FEED BASE
11	19535	*	*	1	送り土台角玉	FEED BAR SLIDE BLOCK
12	19529	*	*	1	送り土台角玉ピン	SLIDE BLOCK PIN
13	19530	*	*	1	送り土台角玉ワッシャー	WASHER
14	50230	*	*	1	送り土台止めねじ	SCREW 3/16X32 L=5.0
15	18031	*	*	1	送り歯	FEED DOG
16	19525	*	*	2	止めねじ	SCREW 1/8X40 L=6.0
17	18122	*	*	1	二又ロッド	FEED FORKED CONNECTION
18	18121	*	*	1	二又ロッド補助ねじ	HINGE SCREW M3X0.5
19	4211	*	*	2	二又ロッド補助ねじナット(小)	NUT M3X0.5 (SMALL)
20	18014	*	*	1	二又ロッドピンねじ	HINGE SCREW 9/32X28
21	17207	*	*	1	メガネリンク	FEED CONNECTING LINK
22	8105	*	*	1	二又ロッドピンねじナット	NUT 9/32X28
23	19527	*	*	1	送り軸だるま(後)	FEED ROCK SHAFT CRANK (BACK)
24	18015	*	*	1	二又ロッド段ねじ	HINGE SCREW 9/32X28
25	8105	*	*	1	二又ロッド段ねじナット	NUT 9/32X28
26	31021	*	*	1	送り軸後だるま締ねじ	PINCH SCREW M6X1 L=16.0
27	17095	*	*	1	送り軸ピンねじ止め輪	"E" RING
28	18539	*	*	1	送り軸後だるまピンねじ	HINGE SCREW M6X1
29	18540	*	*	1	送り軸ピンねじワッシャー	WASHER
30	10599	*	*	1	送り軸後だるまピンねじワッシャー	WASHER
31	11412	*	*	1	送り軸後だるまピンねじナット	NUT M6X1
32	18490	*	*	1	上下送り軸止め輪	RETAINING RING
33	18489	*	*	1	上下送り軸メタル(前)	FEED LIFTING ROCK SHAFT BUSHING(FRONT)
34	8009	*	*	1	止めねじ	SCREW 15/64X28 L=7.5
35	18492	*	*	1	上下送り軸だるま(前)	FEED LIFTING CRANK (FRONT)
36	30066	*	*	1	上下送り軸だるま(前)締ねじ	PINCH SCREW M5X0.8 L=12.0
37	18488	*	*	1	上下送り軸	FEED LIFTING ROCK SHAFT
38	18489	*	*	1	上下送り軸メタル(後)	FEED LIFTING ROCK SHAFT BUSHING (BACK)
39	8009	*	*	1	止めねじ	SCREW 15/64X28 L=7.5
40	18021	*	*	1	上下ロッド	CRANK CONNECTING ROD
41	17041	*	*	1	上下ロッドフェルト	OILING FELT
42	10723	*	*	1	上下ロッドフェルト押え	RETAINER
43	18493	*	*	1	上下送り軸だるま(後)	FEED LIFTING CRANK (BACK)
44	18018	*	*	1	上下送り軸ロッド段ねじ	HINGE SCREW 9/32X28
45	8105	*	*	1	上下送り軸ロッド段ねじナット	NUT 9/32X28
46	18065	*	*	1	上下送り軸だるま(後)締ねじ	PINCH SCREW M5X0.8 L=14.0
47	18491	*	*	1	上下送り軸カラー	LIFTING SHAFT COLLAR
48	19508	*	*	2	止めねじ	SCREW 1/4X40 L=5.5

FEED REGULATOR

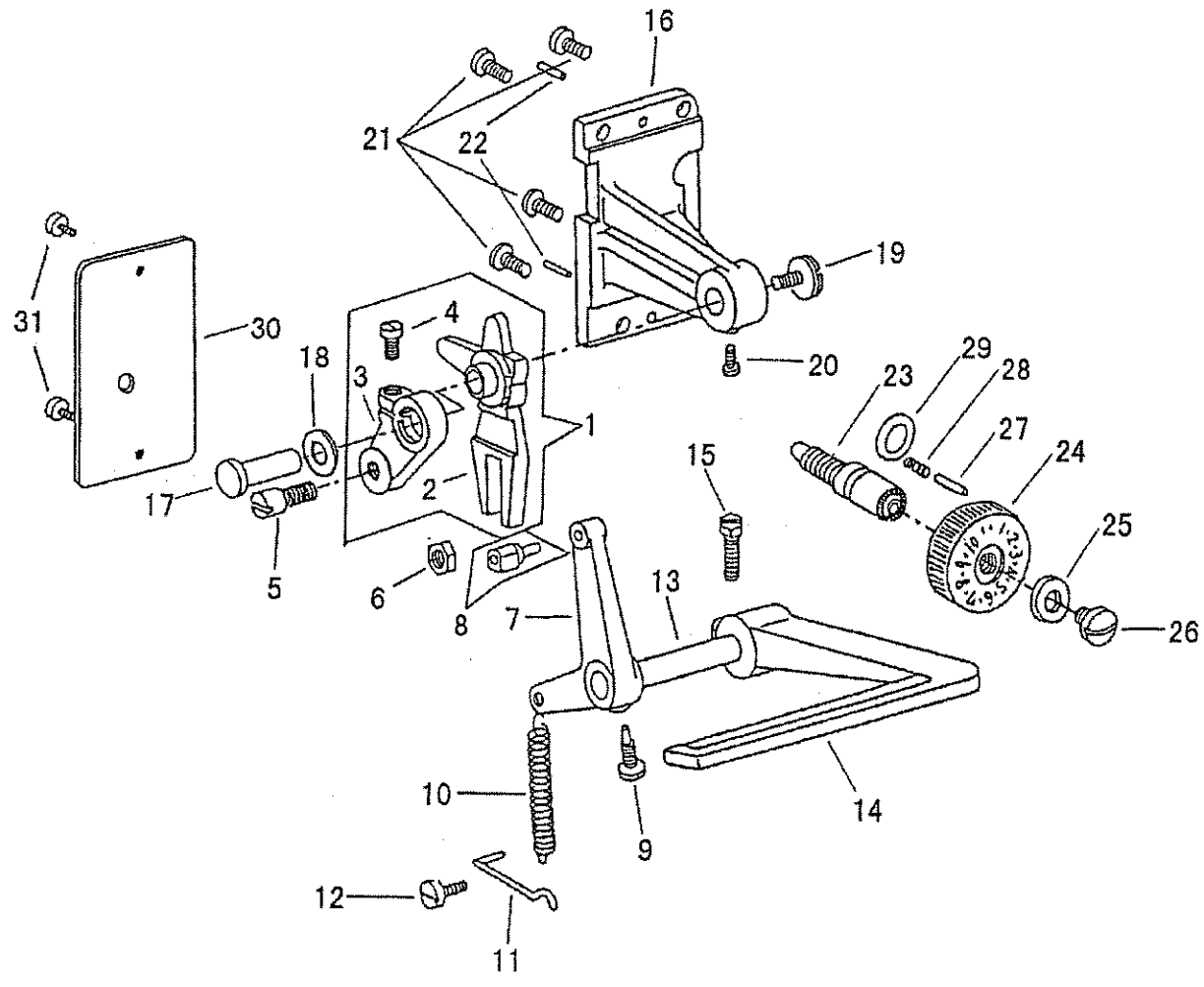

FEED REGULATOR

				Description	
	PARTS NO.	-3	-2		
1	19542C	*		1	送り調節(組) FEED REGULATOR COMPLETE
2	19542	*		1	送り調節 FEED REGULATOR
3	19524	*		1	送り調節ロッド FEED REGULATOR ROD
4	37134	*		1	送り調節ロッド締めねじ PINCH SCREW M4X0.7 L=10.0
5	17209	*	*	1	送り調節ピンねじ FEED REGULATOR SCREW 9/32X28
6	8105	*	*	1	送り調節ピンねじナット NUT 9/32X28
7	18506	*	*	1	バックレバー軸だるま REVERSE LEVER SHAFT CRANK
8	18721C	*	*	1	バック角玉組(ピン付き) REVERSE BLOCK COMPLETE
9	18507	*	*	1	バックレバー軸だるま止めねじ SCREW 15/64X28
10	18515	*	*	1	バックレバースプリング REVERSE LEVER SPRING
11	18516	*	*	1	バックレバースプリング掛け SPRING RETAINER
12	7033	*	*	1	止めねじ SCREW 9/64X40 L=10.8
13	18574	*		1	バックレバー軸 REVERSE LEVER SHAFT
14	19544	*		1	バックレバー REVERSE LEVER
15	10845	*	*	1	バックレバー締めねじ PINCH SCREW 15/64X28 L=18.0
16	19546	*		1	送り調節台 FEED REGULATING BASE
17	18494	*		1	送り調節支持ピン FEED REGULATING SUPPORT STUD
18	17057	*	*	1	送り調節ワッシャー WASHER
19	1392	*		1	送り調節支持ピン押しねじ SCREW 11/64X40 L=6.5
20	19552	*		1	送り調節支持ピン止めねじ SCREW 11/64X28 L=11.5
21	30066	*	*	4	送り調節台止めねじ SCREW M5X0.8 L=12.0
22	50174	*	*	2	送り調節台ノックピン POSITION PIN
23	19523	*		1	送り調節ねじ FEED REGULATING SCREW
24	18496	*		1	送り調節ダイヤル FEED REGULATING DIAL
25	B142746	*		1	ダイヤル座金 WASHER
26	19522	*		1	止めねじ SCREW 3/16X32 L=20.0
27	B145502	*		1	送り調節ダイヤルピン PIN
28	B100328	*		1	送り調節ダイヤルスプリング SPRING
29	18420	*	*	1	Oリング O RING
30	19543	*		1	アーム横カバー ARM SIDE COVER
31	37509	*		2	アーム横カバー止めねじ SCREW M5X0.8 L=6.0

ARM SHAFT (UPRIGHT), LOWER SHAFT

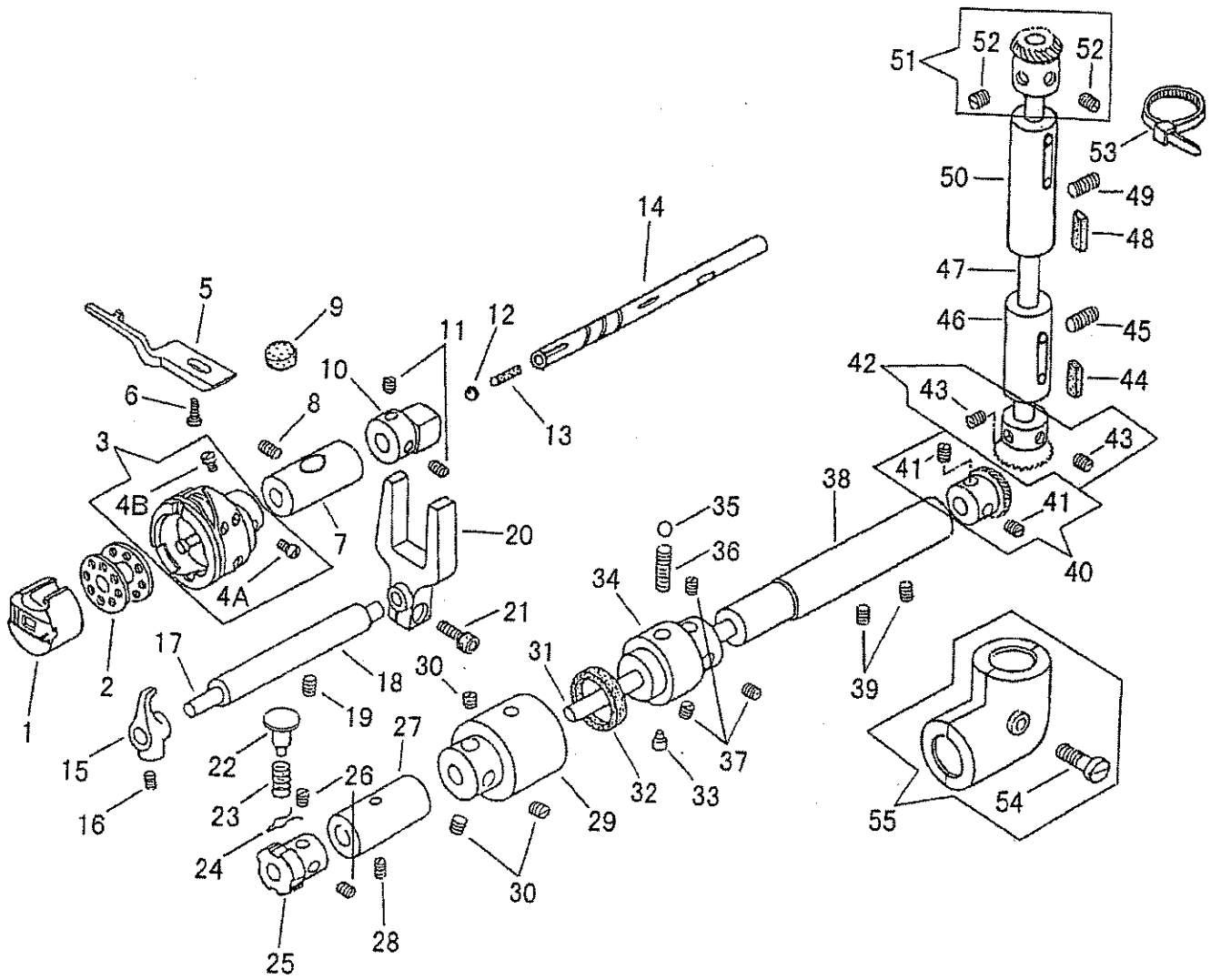

ARM SHAFT (UPRIGHT), LOWER SHAFT

Description

	PARTS NO.	-3	-2			
1	18096	*	*	1	ボビンケースセット	BOBBIN CASE COMPLETE
2	18034	*	*	1	ボビン	BOBBIN
3	18033C	*	*	1	カマセット	ROTATING HOOK COMPLETE
4A	18033-07	*		1	位置決めねじ	POSITION SCREW 11/64X40 L=8.9
4B	18033-08	*		1	止めねじ	SET SCREW 11/64X40 L=7.3
5	18035	*	*	1	カマ受	HOOK SUPPORTING PLATE
6	6025	*	*	1	カマ受止めねじ	SCREW 11/64X40 L=12.0
7	18090	*	*	1	カマ軸メタル(前)	HOOK SHAFT BUSHING (FRONT)
8	8009	*	*	1	カマ軸メタル(前)止めねじ	SCREW 15/64X28 L=7.5
9	11069	*	*	1	フェルト	OILING FELT
10	18044	*	*	1	オープナーカム	HOOK SHAFT CAM
11	8009	*	*	2	止めねじ	SCREW 15/64X28 L=7.5
12	18351	*		1	カマ軸油栓座金	WASHER
13	0148-B	*	*	1	カマ軸フェルト Φ3 X 15	OILING FELT
14	18089	*	*	1	カマ軸	HOOK DRIVING SHAFT
15	18039	*	*	1	ボビンケースオープナー	THREAD RELEASING FINGER
16	18040	*	*	1	オープナー止めねじ	SCREW M5X0.8 L=8.0
17	18041	*	*	1	オープナー軸	THREAD RELEASING SHAFT
18	18042	*	*	1	オープナー軸メタル	THREAD RELEASING SHAFT BUSHING
19	8009	*	*	1	メタル止めねじ	SCREW 15/64X28 L=7.5
20	18043	*	*	1	オープナーニ又	THREAD RELEASING SHAFT FORK
21	30066	*	*	1	オープナーニ又締めねじ	PINCH SCREW M5X0.8 L=12.0
22	18053	*	*	1	押しボタン	PUSH BUTTON
23	18054	*	*	1	押しボタンスプリング	PUSH BUTTON SPRING
24	10674	*	*	1	押しボタン止ピン	CLIP
25	18052	*	*	1	溝車	HOOK SHAFT LOCK RATCHET
26	19508	*		2	溝車止めねじ	SCREW 1/4X40 L=5.0
27	18038-A	*		1	カマ軸メタル(後)	HOOK SHAFT BUSHING (REAR)
28	8009	*	*	1	メタル(後)止めねじ	SCREW 15/64X28 L=7.5
29	18047	*	*	1	クラッチ(左)	SAFETY CLUTCH (LEFT)
30	17019	*	*	3	クラッチ(左)止めねじ	SCREW 1/4X40 L=7.5
31	18056	*	*	1	下軸	LOWER SHAFT
32	18046	*	*	1	クラッチ油芯 6 X 6 X 80	OILING WICK
33	18051	*	*	1	クラッチスプリング止めねじ	SCREW 9/32X28
34	18048	*	*	1	クラッチ(右)	SAFETY CLUTCH (RIGHT)
35	18049	*	*	1	クラッチ鋼球	STEEL BALL
36	18050	*	*	1	クラッチスプリング	SPRING
37	17019	*	*	3	クラッチ(右)止めねじ	SCREW 1/4X40 L=7.5
38	18057	*	*	1	下軸メタル	LOWER SHAFT BUSHING
39	8009	*	*	2	メタル止めねじ	SCREW 15/64X28 L=7.5
40	17028C	*	*	1	下軸ギヤー(ねじ付)	LOWER SHAFT GEAR (SPIRAL) COMPLETE
41	17022	*	*	2	下軸ギヤー止めねじ	SET SCREW 1/4X40 L=5.0
42	17023C	*	*	1	立軸ギヤー(下)(ねじ付)	ARM SHAFT (UPRIGHT) GEAR (LOWER)(SPIRAL) COMPLETE
43	17022	*	*	2	立軸ギヤー(下)止めねじ	SET SCREW 1/4X40 L=5.0
44	17026	*	*	1	立軸下メタルフェルト	OILING FELT
45	10579	*	*	1	メタル(下)止めねじ	SET SCREW 15/64X28 L=20.0
46	19553	*		1	立軸メタル(下)	ARM SHAFT (UPRIGHT) BUSHING (LOWER)
47	17020	*	*	1	立軸	ARM SHAFT (UPRIGHT)
48	17026	*	*	1	立軸メタル(上)フェルト	OILING FELT
49	10579	*	*	1	メタル(上)止めねじ	SCREW 15/64X28 L=20.0
50	19554	*		1	立軸メタル(上)	ARM SHAFT (UPRIGHT) BUSHING (UPPER)
51	17021C	*	*	1	立軸ギヤー(上)(ねじ付)	ARM SHAFT (UPRIGHT) GEAR (SPIRAL) COMPLETE
52	17022	*	*	2	立軸ギヤー(上)止めねじ	SET SCREW 1/4X40 L=5.0
53	30750	*		1	立軸メタル(上)バンド	BAND
54	18058C	*	*	1	ギヤーカバー(下)(ねじ付)	GEAR COVER (LOWER) (SPIRAL) COMPLETE
55	18059	*	*	1	ギヤーカバー(下)締めねじ	PINCH SCREW 15/64X28 L=26

LUBRICATION

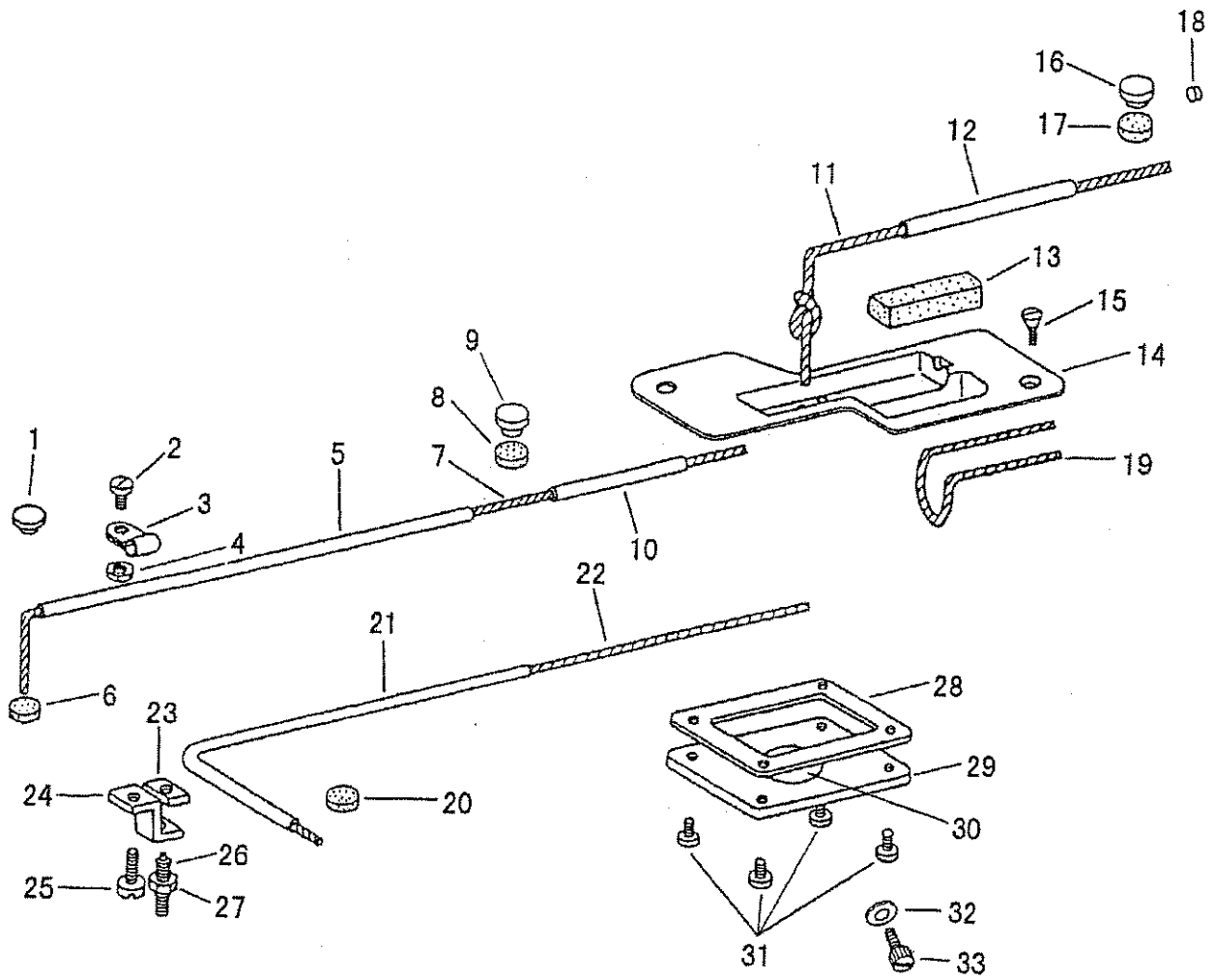

LUBRICATION

Description

	PARTS NO.	-3	-2		
1	20171	*	*	1	上軸メタル(前)ゴム栓 RUBBER PLUG
2	4124	*	*	1	油芯止めねじ SCREW M4X0.7 L=9.5
3	30022	*	*	1	油芯止クランプ OILING WICK CLAMP
4	31206	*	*	1	油芯止ナット NUT
5	18112	*	*	1	ビニールチューブ OIL TUBE 160MM
6	11069	*	*	1	上軸メタル(前)フェルト OILING FELT
7	18110	*	*	1	油芯 OILING WICK 380MM
8	11069	*	*	1	上軸メタル(中間)フェルト OILING FELT
9	20171	*	*	1	上軸メタル(中間)ゴム栓 RUBBER PLUG
10	18113	*	*	1	ビニールチューブ OIL TUBE 35MM
11	18109	*	*	1	油芯 OILING WICK 220MM
12	18111	*	*	1	ビニールチューブ OIL TUBE 75MM
13	18104	*	*	1	オイル上タンクフェルト FELT
14	19106	*	*	1	オイル上タンク OIL RESERVOIR
15	11044	*	*	1	オイル上タンク(右)止めねじ SCREW 1/8X40 L=7.0
16	20171	*	*	1	上軸メタル(後)ゴム栓 RUBBER PLUG
17	11069	*	*	1	上軸メタル(後)フェルト OILING FELT
18	20067	*	*	1	上軸油ゴム栓 RUBBER PLUG
19	18108	*	*	1	油芯 OILING WICK 160MM
20	11069	*	*	1	ガマ軸メタル(前)フェルト OILING FELT
21	18100	*	*	1	ビニールチューブ OIL TUBE 80MM
22	18101	*	*	1	油芯 OILING WICK 180MM
23	18094	*	*	1	油調節押し板 OIL CONTROLLER
24	18093	*	*	1	油調節受板 OIL CONTROLLER PLATE
25	21104	*	*	1	油調節受板止めねじ SCREW 11/64X40 L=7.5
26	18095	*	*	1	油調節ねじ REGULATING SCREW M4X0.7 L=16.0
27	4137	*	*	1	油調節ねじナット NUT M4X0.7
28	18354	*	*	1	オイル板パッキン OIL RESERVOIR GASKET
29	19545	*	*	1	オイル板 OIL RESERVOIR PLATE
30	18353	*	*	1	オイル窓 OIL RESERVOIR WINDOW
31	15007	*	*	4	オイル板止めねじ SCREW 9/64X40 L=10.0
32	18092	*	*	1	油栓パッキング OIL PACKING
33	18091	*	*	1	油栓ねじ SCREW 11/64X40

ACCESSORIES

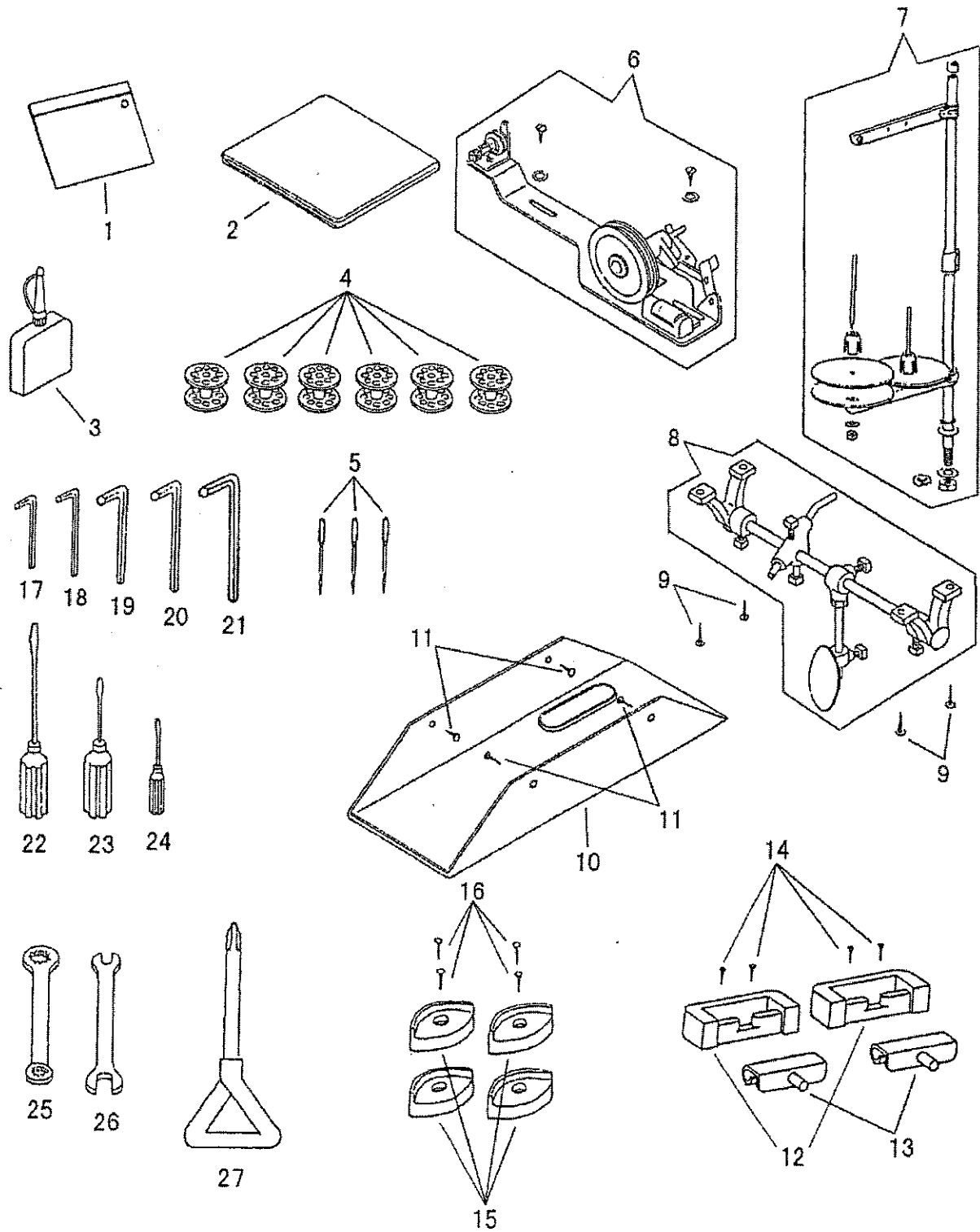

ACCESSORIES

	PARTS NO.	-3	-2		
1	8132-B	*	*	1	部品袋 ACCESSORIES BAG
2	6057	*	*	1	ビニールカバー(小) VINYL COVER
3	8123	*	*	1	油 OIL
4	18034	*	*	6	ボビン BOBBIN
5	N0122	*	*	3	針 DP X 17 #22 NEEDLE DP X 17 #22
6	10734	*	*	1	糸巻セット BOBBIN WINDER COMPLETE
7	35254	*	*	1	糸立セット SPOOL PIN COMPLETE
8	19464	*	*	1	ひざ上げセット KNEE LIFTER COMPLETE
9	19464-14	*	*	4	木ねじ(4.5 X 25L) SCREW
10	6054	*	*	1	油受 OIL PAN COMPLETE
11	6055	*	*	4	油受止釘 NAIL
12	11886	*	*	2	ヒンジラバー BED HINGE RUBBER
13	11885	*	*	2	ヒンジ BED HINGE CONNECTION
14	6055	*	*	4	ヒンジラバー止釘 NAIL
15	11887	*	*	4	コーナーゴム RUBBER
16	6055	*	*	4	コーナーゴム止釘 NAIL
17	19456	*	*	1	六角レンチ (2 MM) WRENCH 2.0 MM
18	19457	*	*	1	六角レンチ (2.5 MM) WRENCH 2.5 MM
19	19458	*	*	1	六角レンチ (3 MM) WRENCH 3.0 MM
20	19459	*	*	1	六角レンチ (4 MM) WRENCH 4.0 MM
21	19460	*	*	1	六角レンチ (5 MM) WRENCH 5.0 MM
22	19466	*	*	1	ドライバー(大) SCREW DRIVER (LARGE)
23	19467	*	*	1	ドライバー(中) SCREW DRIVER (MIDDLE)
24	19468	*	*	1	ドライバー(小) SCREW DRIVER (SMALL)
25	19462	*	*	1	メガネレンチ DOUBLE HEAD WRENCH
26	19461	*	*	1	スパナ (6 X 7 MM) SPANNER 6 X 7 MM
27	8180	*	*	1	十字ドライバー SCREW DRIVER (+)

PARTS AVAILABLE AT EXTRA CHARGE

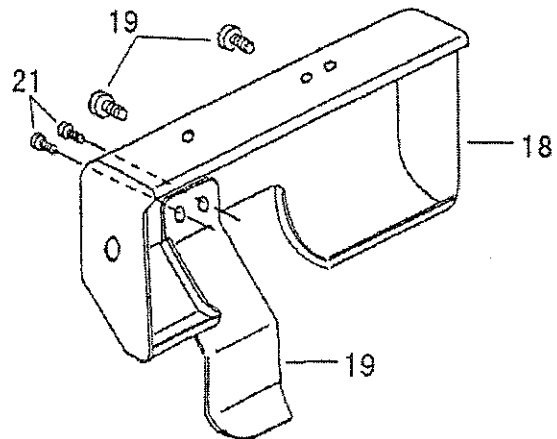
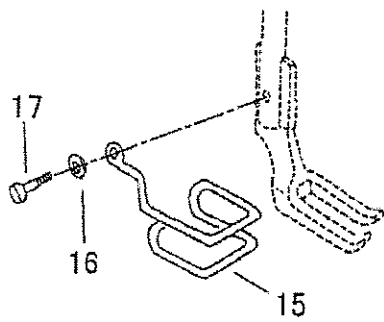
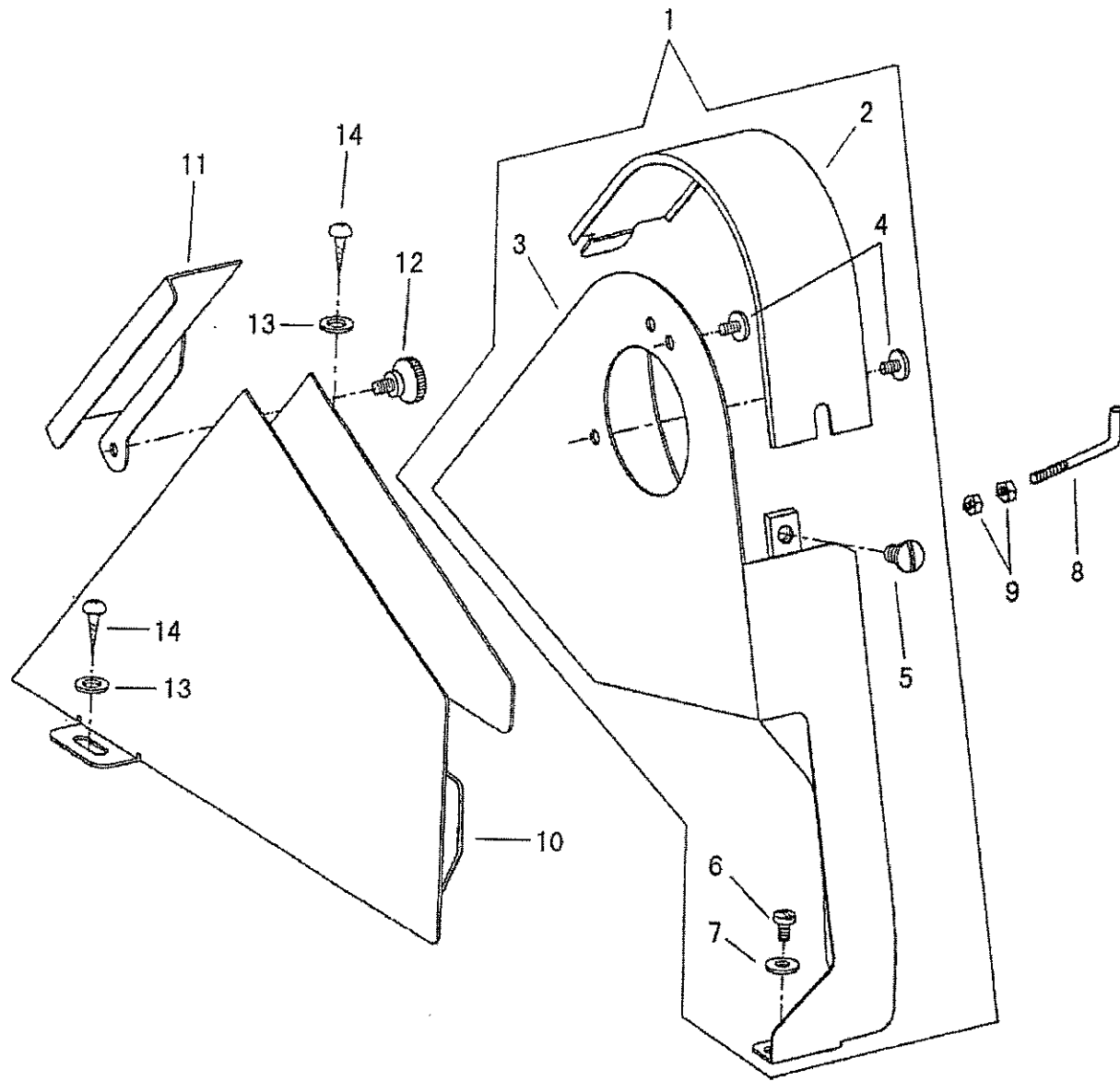

PARTS AVAILABLE AT EXTRA CHARGE

PARTS NO.				Description	
		-3	-2		
1	15098C	*	*	1	ベルトガード(組) BELT GUARD SET
2	15099	*	*	1	ベルトガード上カバー BELT GUARD UPPER COVER
3	15098	*	*	1	ベルトガード BELT GUARD
4	8100	*	*	2	ベルトガード止めねじ SCREW 9/64X40 L=6.5
5	12418	*	*	1	上カバー止めねじ UPPER COVER SCREW 13/64X32 L=9.0
6	8100	*	*	1	ベルトガード止めねじ SCREW (LOWER) 9/64X40 L=6.5
7	11142	*	*	1	ベルトガード止(下)ワッシャー WASHER
8	17372	*	*	1	検出器支え棒 SYNCHRONIZER SUPPORT
9	50409	*	*	2	検出器支え棒止ナット SYNCHRONIZER SUPPORT NUT
10	15121	*	*	1	補助ガード(大) AUXILIARY BELT GUARD (LARGE)
11	15122	*	*	1	補助ガード(小) AUXILIARY BELT GUARD (SMALL)
12	11830	*	*	1	補助ガード(小)止 SCREW 9/64X40 L=5.0
13	16287	*	*	2	補助ガード(大)止ワッシャー WASHER
14	15081	*	*	2	補助ガード(大)木ねじ SCREW
15	10937	*	*	1	フィンガーガード FINGER GUARD
16	10677	*	*	1	ワッシャー WASHER
17	18484	*	*	1	止めねじ SCREW 9/64X40 L=11.0
18	18469	*	*	1	横軸カバー ROCK SHAFT COVER
19	37136	*	*	2	横軸カバー止めねじ SCREW M5X0.8 L=10
20	18469-02	*	*	1	横軸カバー(下) ROCK SHAFT COVER (LOWER)
21	6333	*	*	2	横軸カバー(下)止めねじ SCREW 9/64X40 L=6.5

Consolidated Sewing Machine Corp.

Website: www.consew.com

MAIN office

131 W. 25th Street
New York, NY 10001
Tel: 212-741-7788
Fax: 212-741-7787
e-mail: consew@att.net

Miami, FL

4013 N.W. 79th Avenue
Miami, FL 33166
Tel: 305-471-0200
Fax: 305-471-0243
e-mail: miamisales@consew.com

Los Angeles, CA

2320 South Hill Street
Los Angeles, CA 90007
Tel: 213-745-8844
Fax: 213-745-8855
e-mail: lasales@consew.com